

Inhoudsopgave

Drijfwerkhuis 04	21
Handels & Kabels 00	63
Kappen 04	7
Koppeling 06	15
Schakelpoken 03	59
Stickers 03	79
Stuur & Kabels 04	49
Stuurboom 03	39
Tandwielen 03	27
Type Stickers 03	75
Wielas 01	33
Wielen & Banden 03	69
Parts Index	81

Code	Description	Notes
C01_2_67668	C01_02 - ENGINE GUARDS	
C.01.02.A0011_03	C01_03 - ENGINE GUARDS	
C.01.02.A0011_04	ENGINE GUARDS	
D01_3_59819	D01_03 - CLUTCH	
D01_4_72864	D01_04 - CLUTCH	
D.01.02.A0019_05	D01_05 - CLUTCH	
D.01.02.A0019_06	D01_06 - CLUTCH	
E01_2_67697	GEARBOX	
E.01.02.A0011_03	GEARBOX	
E.01.02.A0011_04	GEARBOX	
F02_2_67738	GEARS	
F.02.02.A0011_03	GEARS	
G05_0_67776	DIFFERENTIAL	
G.05.02.A0011_01	DIFFERENTIAL	
H01_2_67804	STEERING COLUMN	Version: 515GR, 515L GR, 515S GR, 515SL GR
H.01.02.A0011_03	STEERING COLUMN	
I01_2_67839	HANDLEBAR	Version: 515GR, 515L GR, 515S GR, 515SL GR
I.01.02.A0011_03	HANDLEBAR	
I.01.02.A0011_04	HANDLEBAR	
J01_1_67885	CONTROLS	Version: 515GR, 515L GR, 515S GR, 515SL GR
J.01.02.A0011_02	CONTROLS	
J.01.02.A0011_03	CONTROLS	
J.03.02.A0011_00	HANDLEBAR CONTROLS	
L01_2_60486	L01_02 - WHEELS	
L01_3_90714	L01_03 - WHEELS	
M01_2_67927	M01_02 - STICKERS	
M01_3_91676	M01_03 - STICKERS	
M02_2_67938	M02_02 - STICKERS	
M02_3_91699	M02_03 - STICKERS	

500 GR

- (1) ★ 56156990V
- 31121007
- 31421083

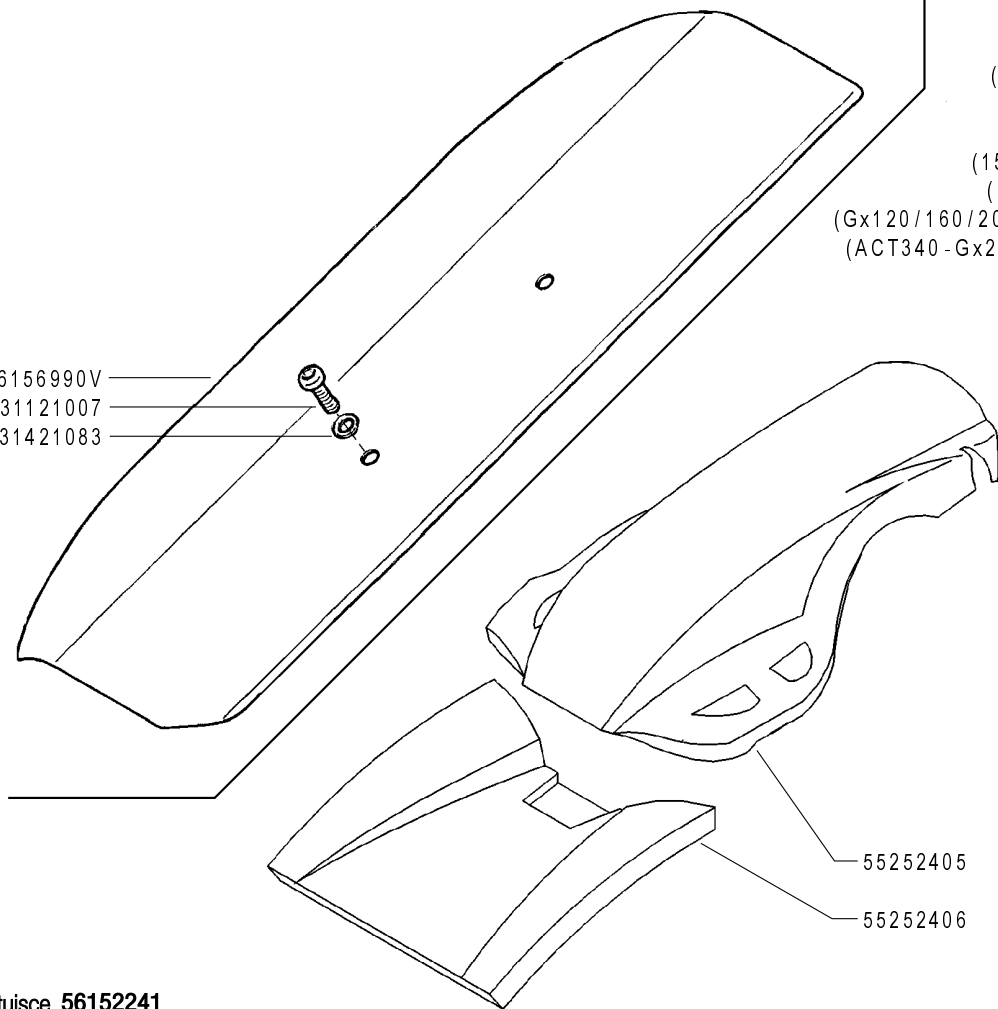

- (15LD350) 31241100
- 31241080
- (15LD350) 31411104
- 31411084
- (15LD350) 31112213
- 31112154
- (15LD350) 59056051N
- (L100AE) 59056111N
- (Gx120/160/200/270) 59056089N
- (ACT340 - Gx240/390) 56156119N
- ★ 31112093
- 58056991 ★
- 56157399N ★
- 56157393N ★
- 31411064 ★
- 31241060 ★
- 58048035 ★
- (HONDA) 58057385

(1) sostituisce 56152241

FERRARI

500 serie **GRIFON**

RIPARI MOTORE

(500GR - 515GR - 515L GR - 515S GR - 515SL GR ★)

ENGINE GUARDS
PROTECCIONES MOTOR

PROTECTIONS MOTEUR
MOTOR SCHUTZ

DALLA MACCHINA
DE LA MAQUINA
DE LA MACHINE
FROM THE MACHINE
AB DER MASCHINE

★N.

AGGIORNAMENTO

REVISION

MISE A JOUR

APLAZAMIENTO

ANPASSUNG

C01

Rev.
2

02/2009

ZENNE

Pos.	Code	Q.ty	Description	Notes
0	0	1		
31112093	31112093	1	SCREW TE M6X20	
31112154	31112154	1	SCREW TE M8X40 UNI 5739 8G	
31112213	31112213	1	SCREW TE M10X40 UNI 5739	
31121007	31121007	1	SCREW BCEI M8X20 ISO7380	
31241060	31241060	1	HEXAGON SELFLOCK NUT M6	
31241080	31241080	1	HEXAGON SELFLOCK NUT M8	
31241100	31241100	1	SELFLOCK HEXAGON NUT M10	
31411064	31411064	1	WASHER 6,4x12,5	
31411084	31411084	1	WASHER 8,4x17	
31411104	31411104	1	WASHER 10,5x18	
31421083	31421083	1	WASHER	
55252405	55252405	1	GUARD	
55252406	55252406	1	GUARD	
58048035	58048035	1	HOLDER	
58056991	58056991	1	CABLE GLAND	
58057385	58057385	1	LINE	
59056111	59056111	1	SHIELD	
56156119	56156119N	1	SHIELD	
56156990	56156990V	1	BODYWORK	
56157393	56157393N	1	HOLDER	
56157399	56157399N	1	HOLDER	
59056051	59056051N	1	SHIELD	
59056089	59056089N	1	SHIELD	

500 GR

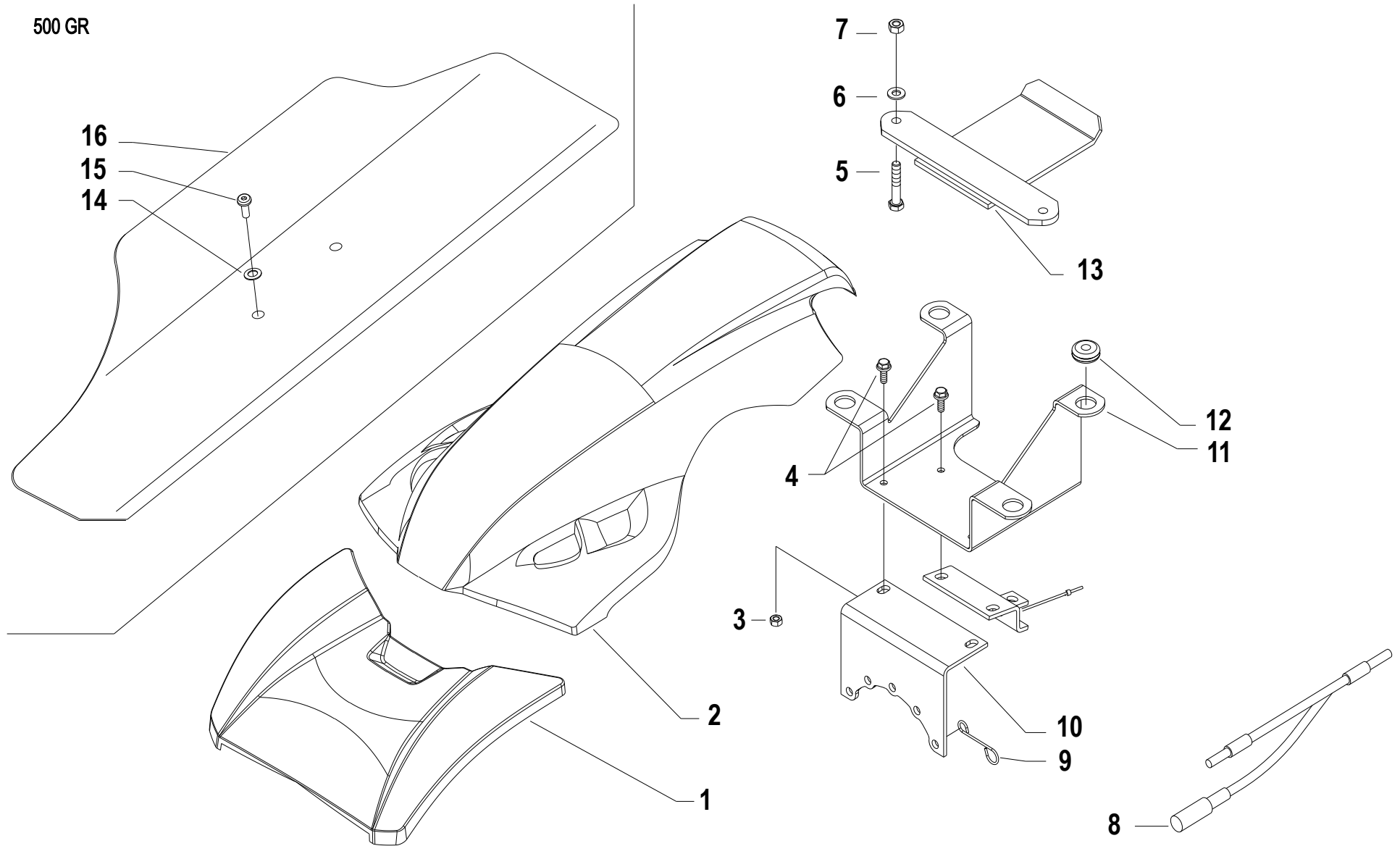

Pos.	Code	Q.ty	Description	Notes
1	55252406	1	GUARD	
2	55252405	1	GUARD	
3	31241065	1	SELFLOCK NUT M6	
4	31112085	1	SCREW TE M6X16 DIN 6921 8G	
5	31112154	1	SCREW TE M8X40 UNI 5739 8G	
5	31112213	1	SCREW TE M10X40 UNI 5739	For the engine 15LD350
6	31411084	1	WASHER 8,4x17	
6	31411104	1	WASHER 10,5x18	For the engine 15LD350
7	31241080	1	HEXAGON SELFLOCK NUT M8	
7	31241100	1	SELFLOCK HEXAGON NUT M10	For the engine 15LD350
8	58057385	1	LINE	
9	58048035	1	HOLDER	
10	56157393N	1	HOLDER	
11	56157399N	1	HOLDER	
12	58056991	1	CABLE GLAND	
13	56156119N	1	SHIELD	For motors ACT340 / GX240 / GX270 / GX390
13	59056051	1	SHIELD	For the engine 15LD350
13	59056089N	1	SHIELD	For motors GX120 / GX160 / GX200 / EX21
13	59056111N	1	SHIELD	For the engine L100AE
14	31421083	1	WASHER	
15	31121007	1	SCREW BCEI M8X20 ISO7380	
16	56156990V	1	BODYWORK	

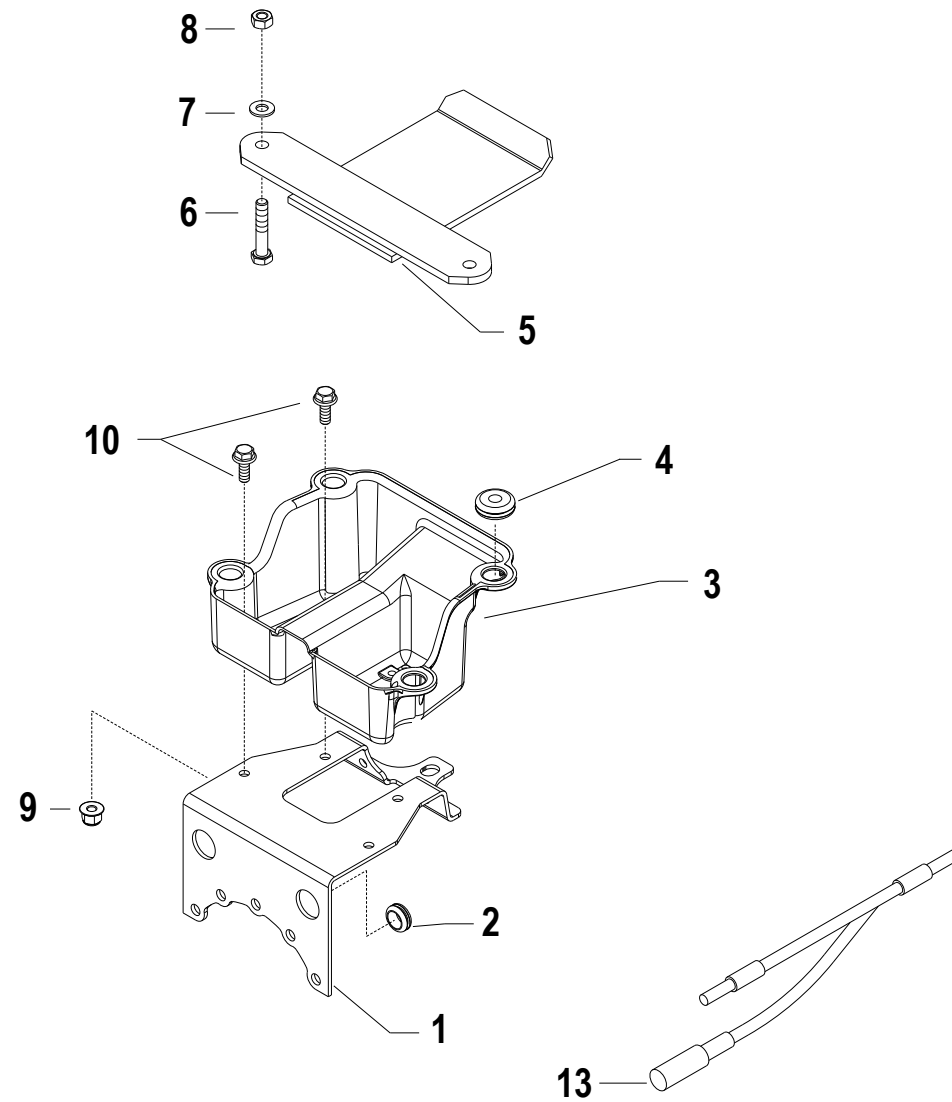
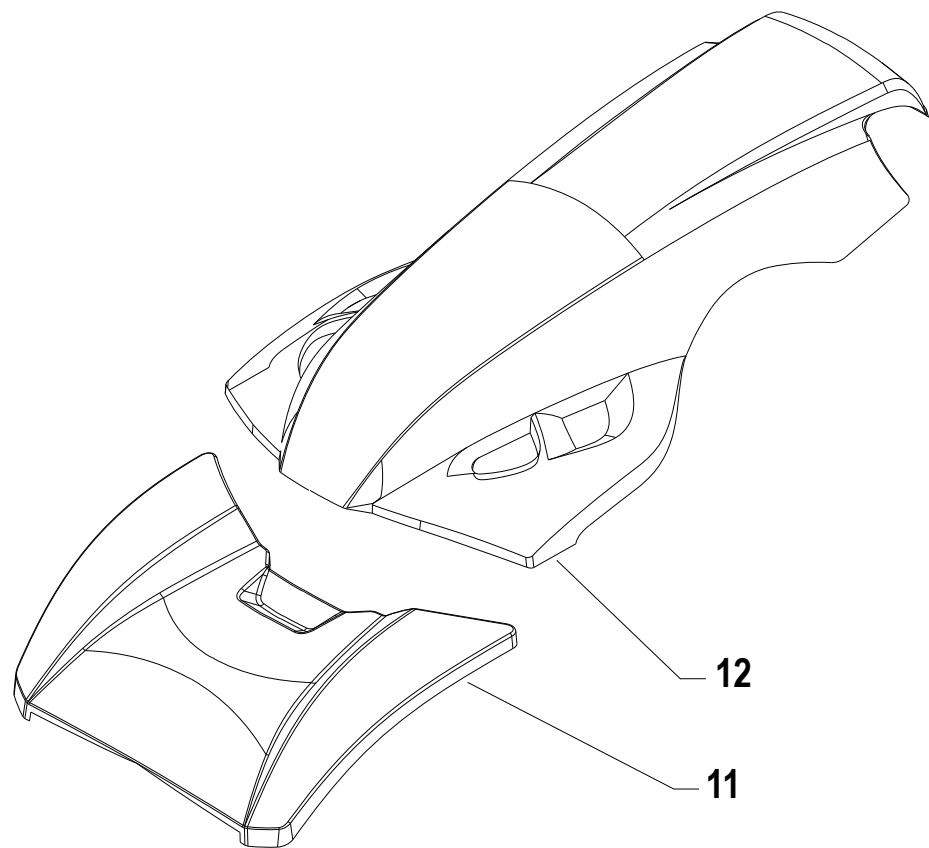

Pos.	Code	Q.ty	Description	Notes
1	561C1002N		HOLDER	
2	581C1004		CABLE GLAND	
3	552C1001		COFANETTO SOST.CARENATURA	Replaces 56157399N
4	58056991		CABLE GLAND	
5	56156119N		SHIELD	ACT340/GX240/GX270/GX390
5	59056051N		SHIELD	15LD350
5	59056089N		SHIELD	GX120/GX160/GX200/EX21
5	59056111N		SHIELD	L100AE
6	31112154		SCREW TE M8X40 UNI 5739 8G	
6	31112213		SCREW TE M10X40 UNI 5739	15LD350
7	31411084		WASHER 8,4x17	
7	31411104		WASHER 10,5x18	15LD350
8	31241080		HEXAGON SELFLOCK NUT M8	
8	31241100		SELFLOCK HEXAGON NUT M10	15LD350
9	31241066		SELFLOCK M6 FL NY DIN 6926	
10	31112081		SCREW TE C/F M6X20 DIN 6921 8G	
11	55252406		GUARD	
12	55252405		GUARD	
13	58057385		LINE	

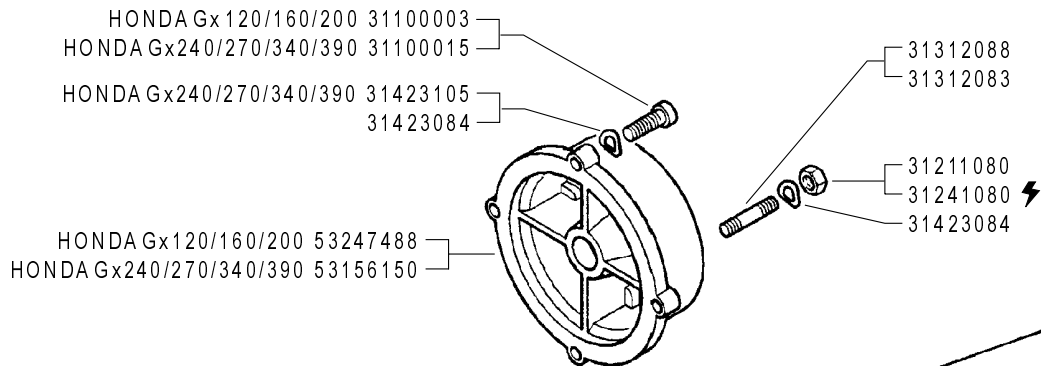

MOTORE ENGINE MOTEUR MOTOR MOTOR	FRIZIONE CLUTCH A EMBRAYAGE EMBRAGUE KUPPLUNG
Acme A220	59247884
Acme ACT 280 - A349 - A360	59247884
Acme ACT 340	59247971
Honda Gx390 - Gx340 D=25,4	59256280
Honda Gx240/270 D=25,4	59256279
Honda Gx120/160/200 D=19	59256275
Lombardini 15LD315/350	59247884
Lombardini 15LD500	59247924
Lombardini LGA 340 ★	59247971
Yanmar L100AE	59247971
Yanmar L70AE	59247884

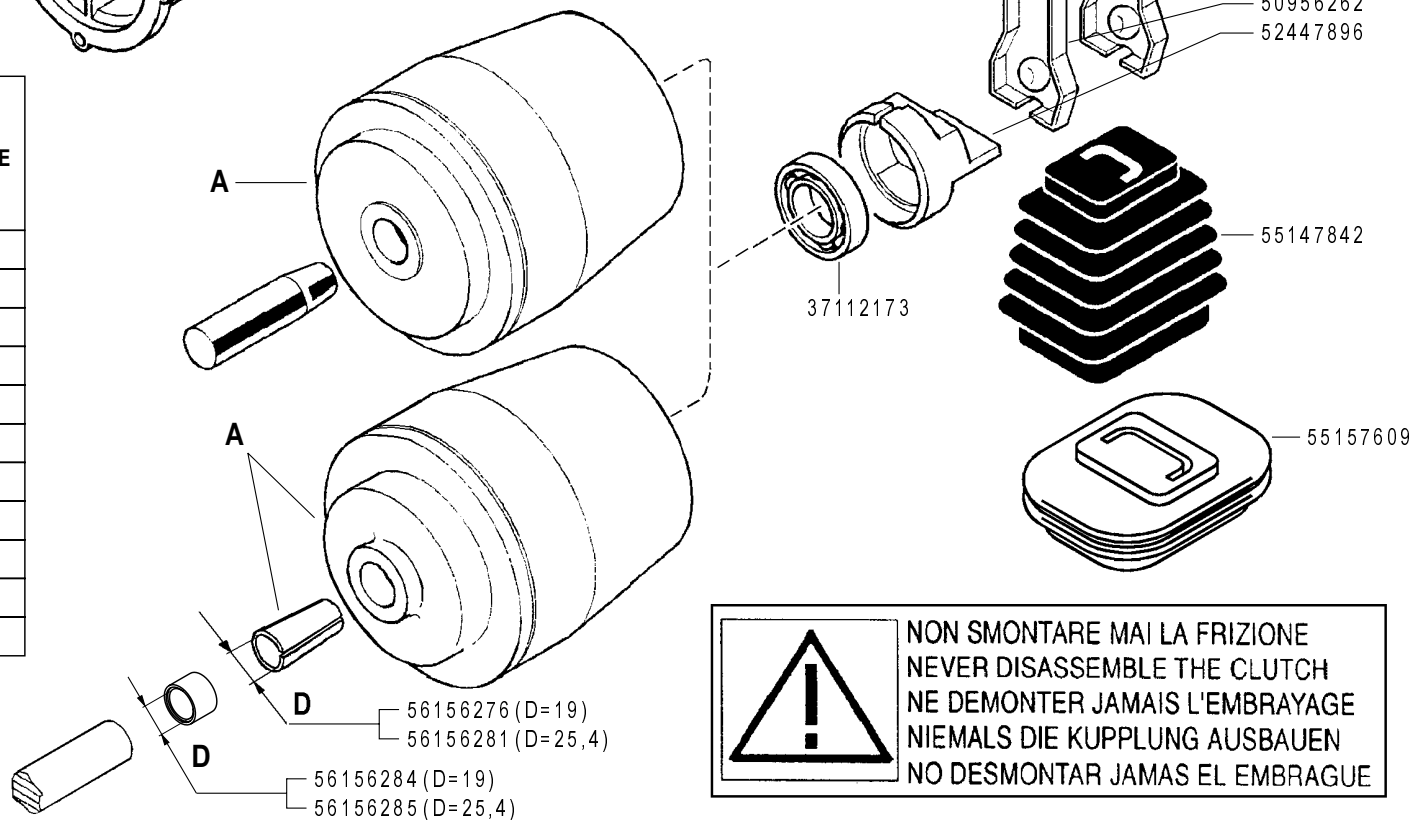

 **NON SMONTARE MAI LA FRIZIONE
NEVER DISASSEMBLE THE CLUTCH
NE DEMONTER JAMAIS L'EMBRAYAGE
NIEMALS DIE KUPPLUNG AUSBAUEN
NO DESMONTAR JAMAS EL EMBRAGUE**

FERRARI

500 serie GRIFON

FRIZIONE A CONO AUTOVENTILANTE

CLUTCH
EMBRAGUE

EMBRAYAGE
KUPPLUNG

DALLA MACCHINA
DE LA MAQUINA
DE LA MACHINE
FROM THE MACHINE
AB DER MASCHINE

AGGIORNAMENTO

REVISION

MISE A JOUR

APLAZAMIENTO

ANPASSUNG

D01

Rev.
3

01/2009

★ N.

ZENNE

Pos.	Code	Q.ty	Description	Notes
31100003	31100003	1	SCREW TE 5/16X7/8	
31100015	31100015	1	SCREW TE 3/8X1	
31211080	31211080	1	NUT M8	
31241080	31241080	1	HEXAGON SELFLOCK NUT M8	
31312083	31312083	1	STUD BOLT M8X46X16X16	
31312088	31312088	1	STUD BOLT M8X40X14X14	
31423084	31423084	1	SPRING WASHER 8,4	
31423105	31423105	1	SPRING WASHER 10,5	
37112173	37112173	1	BEARING	
50956262	50956262	1	CLUTCH LEVER	
52447896	52447896	1	PRESSURE PLATE	
53156150	53156150	1	ENGINE FLANGE	
53247488	53247488	1	ENGINE FLANGE	
55147842	55147842	1	BELLOWS	
55157609	55157609	1	BELLOWS	
56147845	56147845	1	CLUTCH LEVER	
56156276	56156276	1	SLEEVE	
56156281	56156281	1	CENTRING BUSH	
56156284	56156284	1	SPACER	
56156285	56156285	1	SPACER	
59247884	59247884	1	CLUTCH ASSY	
59247924	59247924	1	CLUTCH	
59247971	59247971	1	CLUTCH	
59256275	59256275	1	CLUTCH ASSY	
59256279	59256279	1	CLUTCH ASSY	
59256280	59256280	1	CLUTCH ASSY	

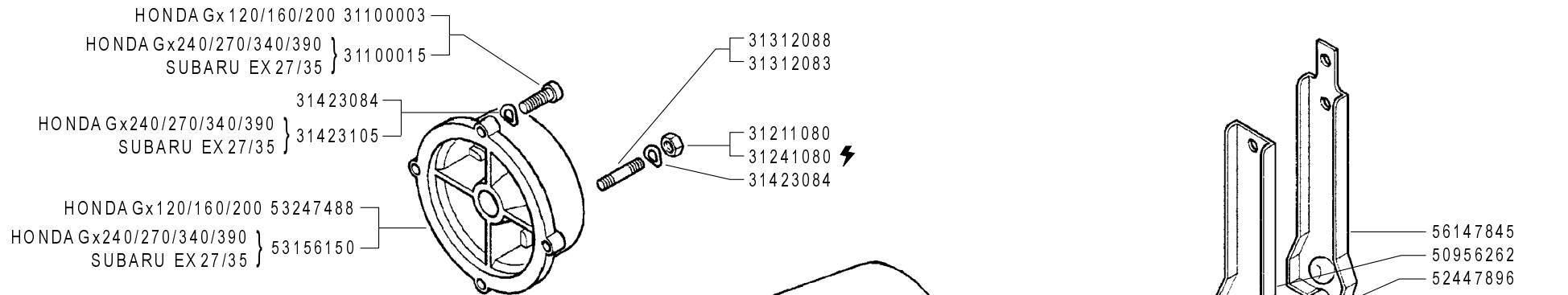

MOTORE ENGINE MOTEUR MOTOR MOTOR	FRIZIONE CLUTCH A EMBRAYAGE EMBRAGUE KUPPLUNG
Acme A220	59247884
Acme ACT 280 - A349 - A360	59247884
Acme ACT 340	59247971
Honda Gx390 - Gx340 D=25,4	59256280
Honda Gx240/270 D=25,4	59256279
Honda Gx120/160/200 D=19	59256275
Lombardini 15LD315/350	59247884
Lombardini 15LD500	59247924
Lombardini LGA 340	59247971
Subaru EX 27 ★	59256279
Subaru EX 35 ★	59256280
Yanmar L100AE	59247971
Yanmar L70AE	59247884

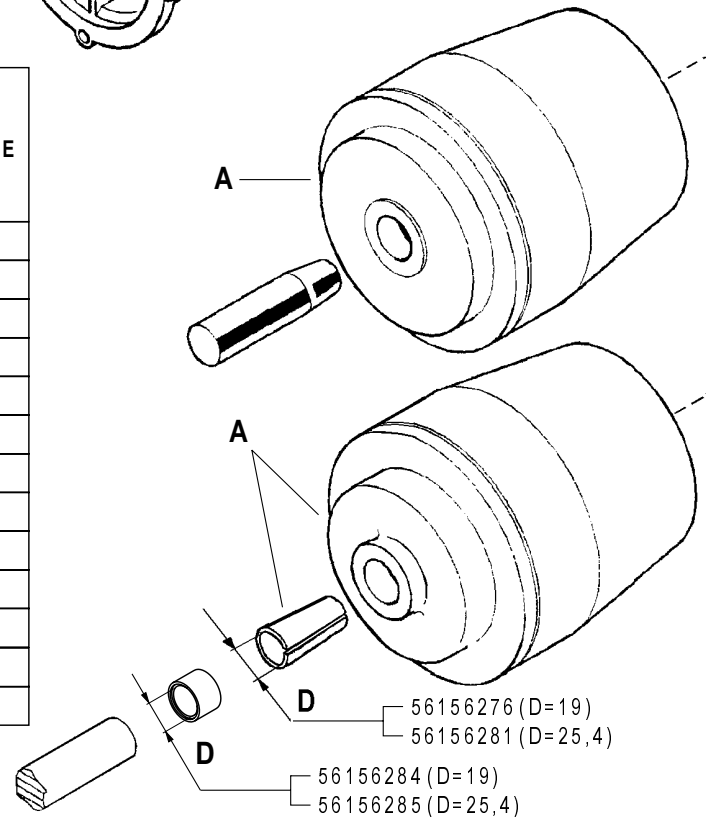

NON SMONTARE MAI LA FRIZIONE
NEVER DISASSEMBLE THE CLUTCH
NE DEMONTER JAMAIS L'EMBRAYAGE
NIEMALS DIE KUPPLUNG AUSBAUEN
NO DESMONTAR JAMAS EL EMBRAGUE

FERRARI

500 serie GRIFON

FRIZIONE A CONO AUTOVENTILANTE

CLUTCH
EMBRAGUE

EMBRAYAGE
KUPPLUNG

DALLA MACCHINA
DE LA MAQUINA
FROM THE MACHINE
AB DER MASCHINE

AGGIORNAMENTO

REVISION

MISE A JOUR

APLAZAMIENTO

ANPASSUNG

D01

Rev. 4

03/2010

★ N.

ZENNE

Pos.	Code	Q.ty	Description	Notes
31100003	31100003	1	SCREW TE 5/16X7/8	
31100015	31100015	1	SCREW TE 3/8X1	
31211080	31211080	1	NUT M8	
31241080	31241080	1	HEXAGON SELFLOCK NUT M8	
31312083	31312083	1	STUD BOLT M8X46X16X16	
31312088	31312088	1	STUD BOLT M8X40X14X14	
31423084	31423084	1	SPRING WASHER 8,4	
31423105	31423105	1	SPRING WASHER 10,5	
37112173	37112173	1	BEARING	
50956262	50956262	1	CLUTCH LEVER	
52447896	52447896	1	PRESSURE PLATE	
53156150	53156150	1	ENGINE FLANGE	
53247488	53247488	1	ENGINE FLANGE	
55147842	55147842	1	BELLOWS	
55157609	55157609	1	BELLOWS	
56147845	56147845	1	CLUTCH LEVER	
56156276	56156276	1	SLEEVE	
56156281	56156281	1	CENTRING BUSH	
56156284	56156284	1	SPACER	
56156285	56156285	1	SPACER	
59247884	59247884	1	CLUTCH ASSY	
59247924	59247924	1	CLUTCH	
59247971	59247971	1	CLUTCH	
59256275	59256275	1	CLUTCH ASSY	
59256279	59256279	1	CLUTCH ASSY	
59256280	59256280	1	CLUTCH ASSY	

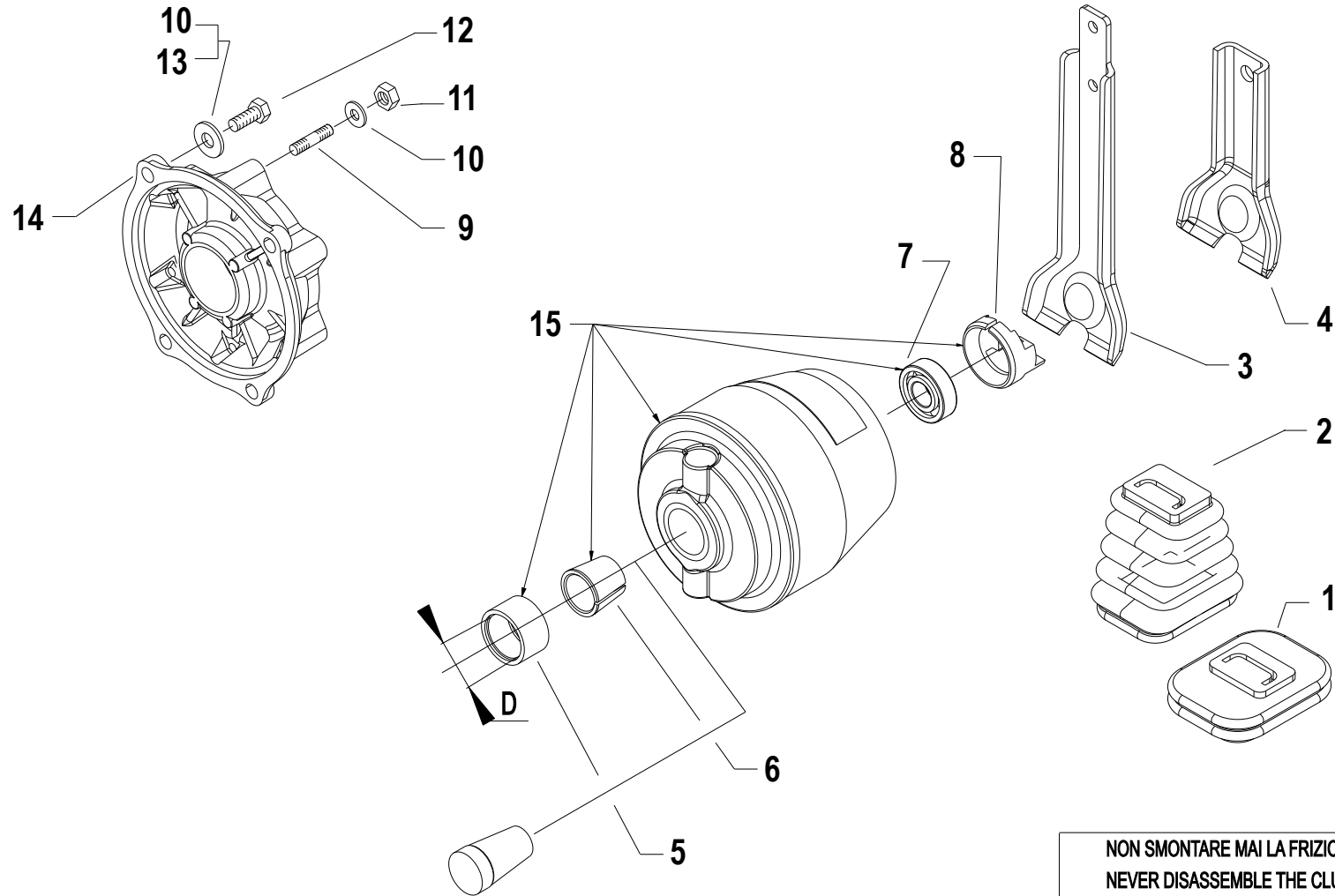

NON SMONTARE MAI LA FRIZIONE
 NEVER DISASSEMBLE THE CLUTCH
 NE DEMONTER JAMAIS L'EMBRAYAGE
 NIEMALS DIE KUPPLUNG AUSBAUEN
 NO DESMONTAR JAMAS EL EMBRAGUE

Pos.	Code	Q.ty	Description	Notes
1	55157609	1	BELLOWS	
2	55147842	1	BELLOWS	
3	56147845	1	CLUTCH LEVER	
4	50956262	1	CLUTCH LEVER	
5	56156284	1	SPACER	
5	56156285	1	SPACER	
6	56156276	1	SLEEVE	
6	56156281	1	CENTRING BUSH	
7	37112173	1	BEARING	
8	52447896	1	PRESSURE PLATE	
9	31312083	1	STUD BOLT M8X46X16X16	For motors EX21/LGA340/15LD350/L100AE/ACT340
9	31312088	1	STUD BOLT M8X40X14X14	For motors GX340/GX390/EX35
10	31423084	1	SPRING WASHER 8,4	
11	31211080	1	NUT M8	
11	31241080	1	HEXAGON SELFLOCK NUT M8	For engines with electric start
12	31100003	1	SCREW TE 5/16X7/8	For motors GX120/GX160/GX200/EX21
12	31100015	1	SCREW TE 3/8X1	For motors GX240/GX270/GX340/GX390/EX27/EX35
13	31423105	1	SPRING WASHER 10,5	For motors GX240/GX270/GX340/GX390
14	53156150	1	ENGINE FLANGE	For motors GX240/GX270/GX340/GX390/EX27/EX35
14	53247488	1	ENGINE FLANGE	For motors GX120/GX160/GX200/EX21
15	59247884		CLUTCH ASSY	15LD315/15LD350 - ACME A220/ACME ACT 280/A349/A360 -
15	59247924		CLUTCH	15LD500
15	59247971		CLUTCH	L100AE - ACT340 - LGA340
15	59256275		CLUTCH ASSY	GX160/GX200 - EX21
15	59256279		CLUTCH ASSY	GX240/GX270 - EX27
15	59256280		CLUTCH ASSY	GX340/GX390 - EX35
15	59256295		CLUTCH ASSY	A220 (REF.)

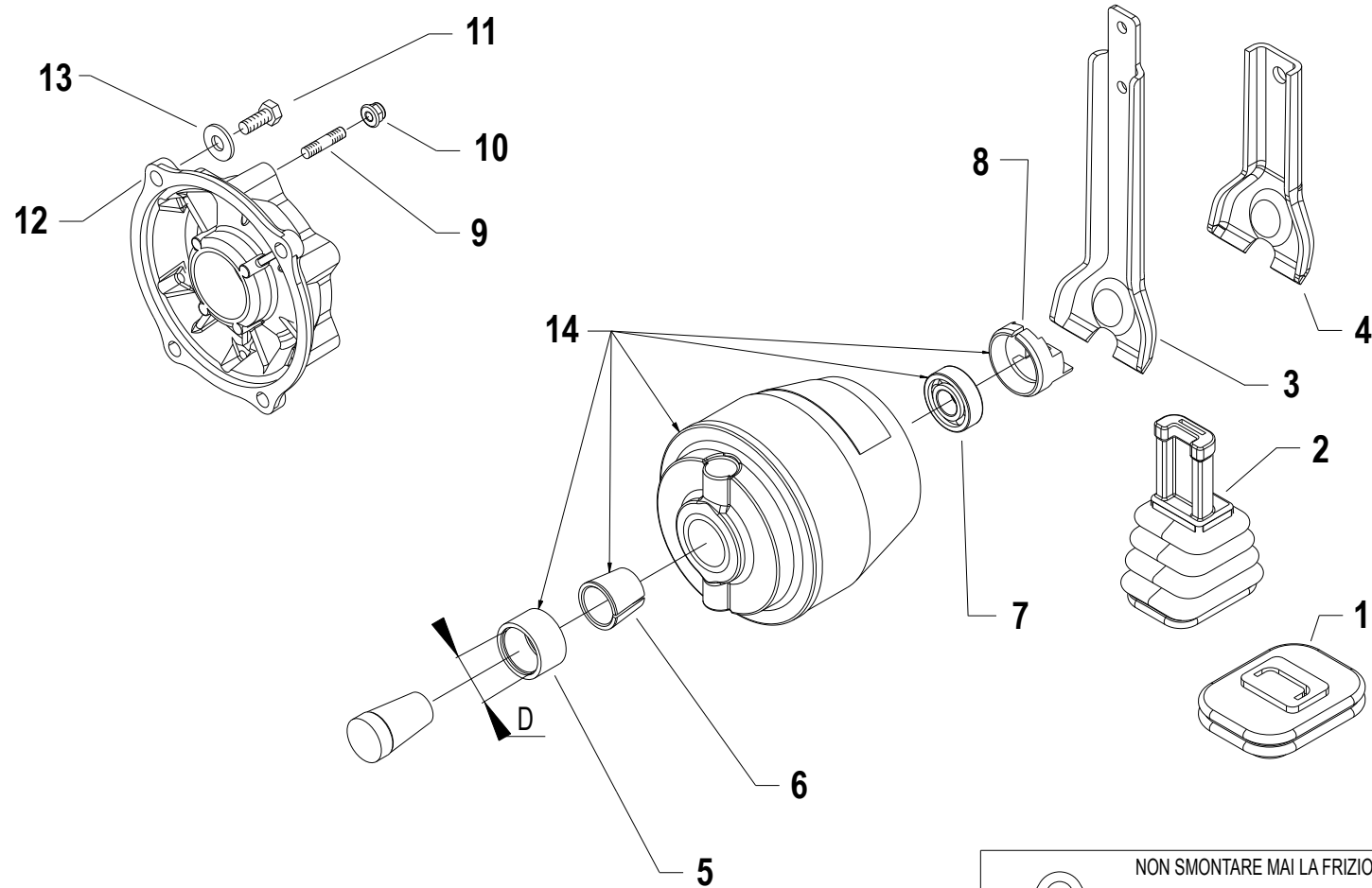

 NON SMONTARE MAI LA FRIZIONE
NEVER DISASSEMBLE THE CLUTCH
NE DEMONTER JAMAIS L'EMBRAYAGE
NIEMALS DIE KUPPLUNG AUSBAUEN
NO DESMONTAR JAMAS EL EMBRAGUE

Pos.	Code	Q.ty	Description	Notes
1	55157609		BELLOWS	
2	55156481		BELLOWS	Replaces 55147842
3	56147845		CLUTCH LEVER	
4	50956262		CLUTCH LEVER	
5	56156284		SPACER	
5	56156285		SPACER	
6	56156276		SLEEVE	
6	56156281		CENTRING BUSH	
7	37112173		BEARING	
8	52447896		PRESSURE PLATE	
9	31312083		STUD BOLT M8X46X16X16	
10	31241083		SELFLOCK NUT M8	Replaces 31211080 + 31423084
11	31100003		SCREW TE 5/16X7/8	For engines GX120-GX160-GX200-EX21
11	31100015		SCREW TE 3/8X1	For engines GX240-GX270-GX340-GX390-EX27-EX35
12	53156150		ENGINE FLANGE	For engines GX240-GX270-GX340-GX390-EX27-EX35
12	53247488		ENGINE FLANGE	For engines GX120-GX160-GX200-EX21
13	31423084		SPRING WASHER 8,4	
13	31423105		SPRING WASHER 10,5	For engines GX240-GX270-GX340-GX390-EX27-EX35
14	59247489		CONIC CLUTCH D=23 1 CPL SPRING	REPLACES 59247884 - 15LD315/15LD350 - A220 -
14	59247513		CONIC CLUTCH D=24 2 SPRINGS	REPLACES 59247924 - 15LD500
14	59247823		CONIC CLUTCH D=23,2 2 SPRINGS	REPLACES 59247971 - L100 - ACT340 - LGA340
14	592C1010		CLUTCH D.19 Q(UP TO 9HP)	REPLACES 59256275 - GX120/GX160/GX200 - EX21
14	592C1011		COMPLETE CLUTCH D=25,4 9HP	REPLACES 59256275 - GX240/GX270 - EX27
14	592C1012		CONIC CLUTCH D=25,4 UP 9HP	REPLACES 59256280 - GX340/GX390 - EX35
14	592C1013		FRIZIONE C.TA 1 MOLLA SP. REF.	REPLACES 59256295 - A220 REFORM

SERIAL
START
959257

D01_06 - CLUTCH

CODE REV
D.01.02.A0019_06

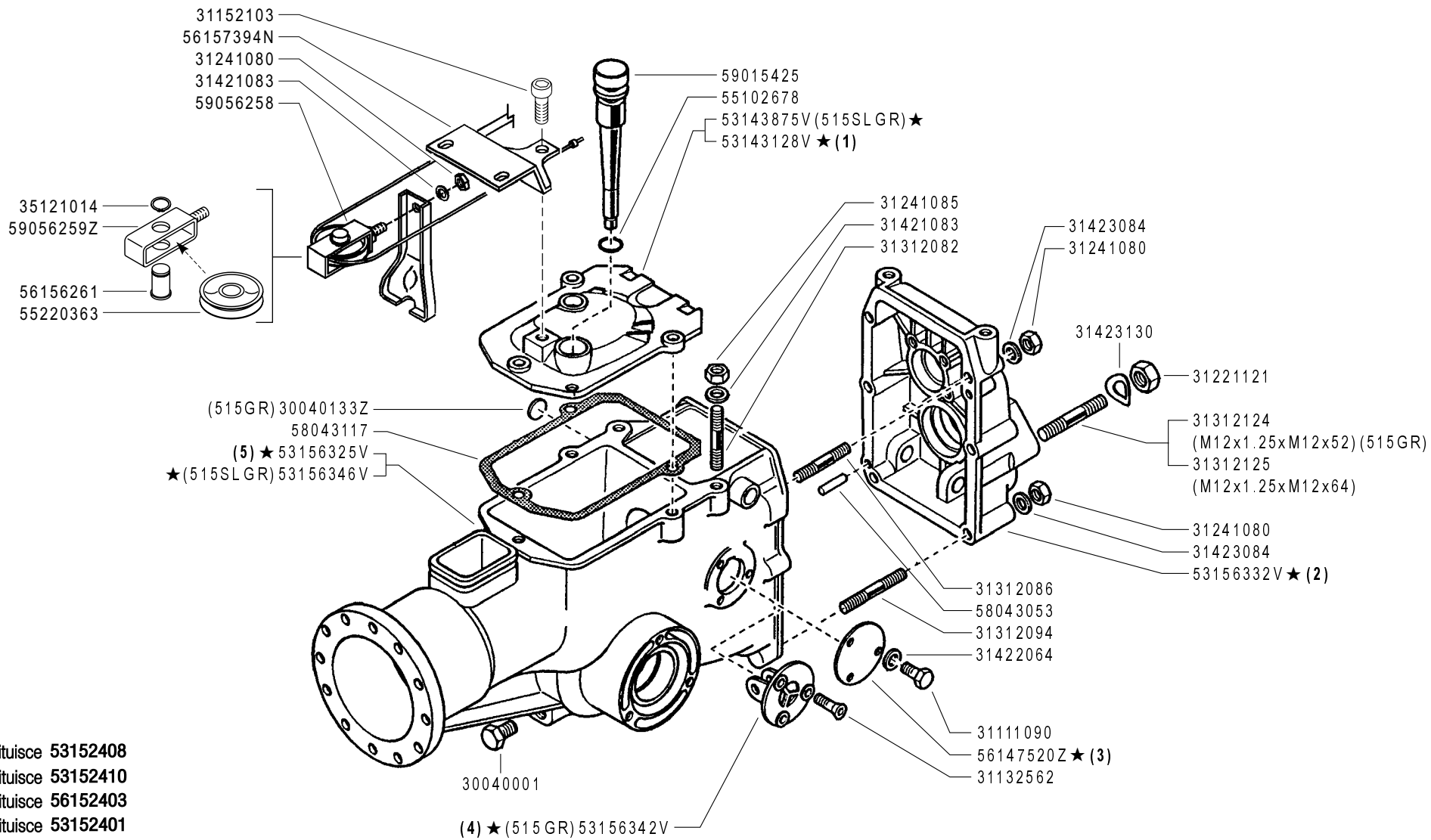

- (5) sostituisce 53152408
- (4) sostituisce 53152410
- (3) sostituisce 56152403
- (2) sostituisce 53152401
- (1) sostituisce 53152409

FERRARI

500 serie GRIFON

**SCATOLA CAMBIO
(515GR - 515L GR - 515S GR - 515SL GR ★)**

GEARBOX
CAJA DE CAMBIO

BOITE DE VITESSES
WECHSELGETRIEBE

DALLA MACCHINA
DE LA MAQUINA
DE LA MACHINE
FROM THE MACHINE
AB DER MASCHINE

★N.

AGGIORNAMENTO
REVISION
MISE A JOUR
APLAZAMIENTO
ANPASSUNG

E01

Rev.
2

02/2009

ZENNE

Pos.	Code	Q.ty	Description	Notes
30040001	30040001	1	PLUG	
31111090	31111090	1	SCREW TE M5X10 UNI 5739 8G	
31132562	31132562	1	SCREW TSVEI M6X16 UNI 5933	
31152103	31152103	1	SCREW TCEI M10X25 UNI 5931	
31221121	31221121	1	NUT M12X1,25	
31241080	31241080	1	HEXAGON SELFLOCK NUT M8	
31241085	31241085	1	SELFLOCK NUT M8 6S	
31312082	31312082	1	STUD BOLT M8X38X14X20	
31312086	31312086	1	STUD BOLT M8X56X20X14	
31312094	31312094	1	STUD BOLT M8X68X14X36	
31312124	31312124	1	STUD BOLT	
31312125	31312125	1	STUD BOLT	
31421083	31421083	1	WASHER	
31422064	31422064	1	SPRING WASHER 6,4	
31423084	31423084	1	SPRING WASHER 8,4	
31423130	31423130	1	SPRING WASHER 13	
35121014	35121014	1	SEEGER RING	
55102678	55102678	1	RUBBER RING	
55220363	55220363	1	PULLEY	
56156261	56156261	1	PIN	
58043053	58043053	1	CYLINDRICAL PLUG	
58043117	58043117	1	COVER GASKET	
59015425	59015425	1	PLUG	
59056258	59056258	1	CLUTCH FORK	
30040133	30040133Z	1	PLUG 22 DIN 470	
53143128	53143128V	1	COVER	
53143875	53143875V	1	GEARBOX HOUSING COVER	
53156325	53156325V	1	BODY	
53156332	53156332B	1	REAR COVER	
53156342	53156342V	1	GEAR SUPPORT	
53156346	53156346V	1	BODY	
56147520	56147520Z	1	COVER	
56157394	56157394N	1	STOP	
59056259	59056259Z	1	CLUTCH FORK	

SERIAL

GEARBOX

CODE REV

E01_2_67697

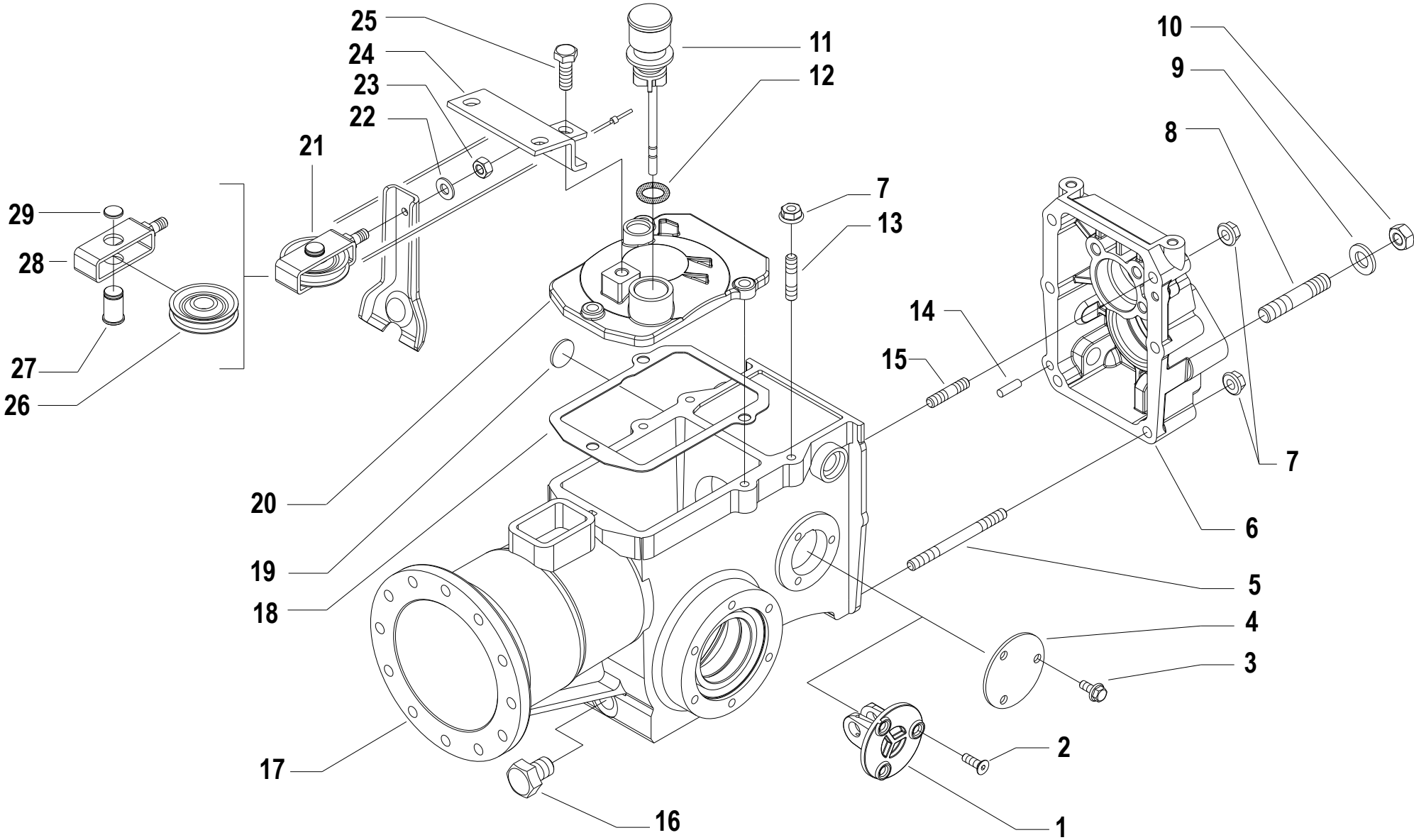

Pos.	Code	Q.ty	Description	Notes
1	53156342V	1	GEAR SUPPORT	
2	31132562	1	SCREW TSVEI M6X16 UNI 5933	
3	31112083	1	SCREW M6X12	
4	56147520Z	1	COVER	
5	31312094	1	STUD BOLT M8X68X14X36	
6	53156332V	1	REAR COVER	
7	31241084	1	SELFLOCK NUT M8 6S	
8	31312124	1	STUD BOLT	For the model 515G
8	31312125	1	STUD BOLT	
9	31421130	1	WASHER	
10	31221121	1	NUT M12X1,25	
11	59015425	1	PLUG	
12	55102678	1	RUBBER RING	
13	31312082	1	STUD BOLT M8X38X14X20	
14	58043053	1	CYLINDRICAL PLUG	
15	31312086	1	STUD BOLT M8X56X20X14	
16	30040001	1	PLUG	
17	53156325V	1	BODY	
17	53156346V	1	BODY	For the model 515SLGR
18	58043117	1	COVER GASKET	
19	30040133Z	1	PLUG 22 DIN 470	For the model 515GR
20	53143128V	1	COVER	
20	53143875V	1	GEARBOX HOUSING COVER	
21	59056258	1	CLUTCH FORK	
22	31421083	1	WASHER	
23	31241080	1	HEXAGON SELFLOCK NUT M8	
24	56157394N	1	STOP	
25	31152103	1	SCREW TCEI M10X25 UNI 5931	
26	55220363	1	PULLEY	
27	56156261	1	PIN	
28	59056259Z	1	CLUTCH FORK	
29	35121014	1	SEEGER RING	

GEARBOX

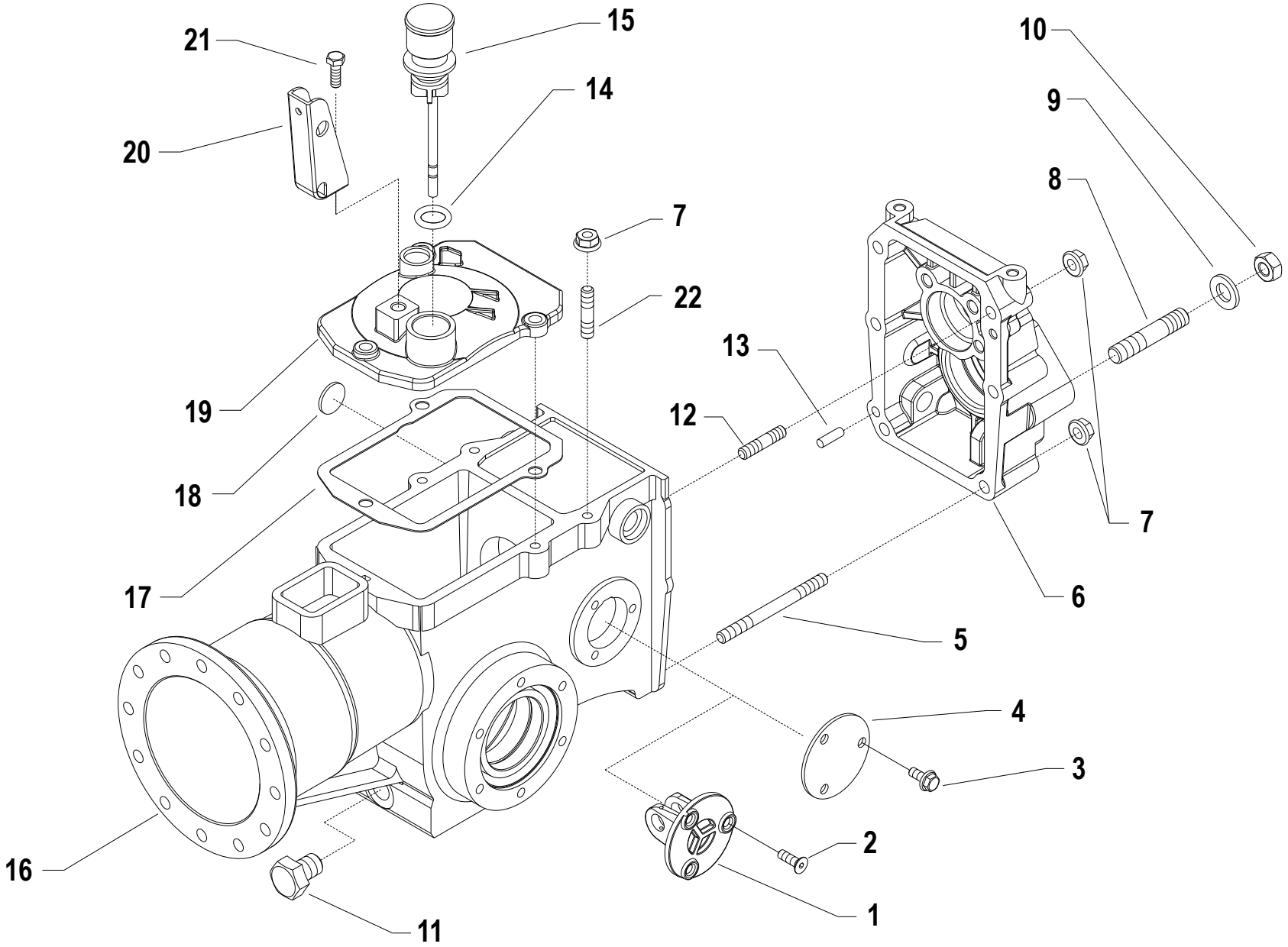

Pos.	Code	Q.ty	Description	Notes
1	53156342V		GEAR SUPPORT	515GR
2	31132562		SCREW TSVEI M6X16 UNI 5933	
3	31112083		SCREW M6X12	
4	56147520Z		COVER	
5	31312094		STUD BOLT M8X68X14X36	
6	53156332V		REAR COVER	
7	31241084		SELFLOCK NUT M8 6S	
8	31312124		STUD BOLT	515GR
8	31312125		STUD BOLT	
9	31421130		WASHER	
10	31221121		NUT M12X1,25	
11	30040001		PLUG	
12	31312086		STUD BOLT M8X56X20X14	
13	58043053		CYLINDRICAL PLUG	
14	55102678		RUBBER RING	
15	59015425		PLUG	
16	53156325V		BODY	
16	53156346V		BODY	515SLGR
17	58043117		COVER GASKET	
18	30040133Z		PLUG 22 DIN 470	515GR
19	53143128V		COVER	
19	53143875V		GEARBOX HOUSING COVER	515SLGR
20	56147923N		BRACKET	Replaces 59056258 + 31421083 +31241080 + 56157394N
21	31152103		SCREW TCEI M10X25 UNI 5931	
22	31312082		STUD BOLT M8X38X14X20	

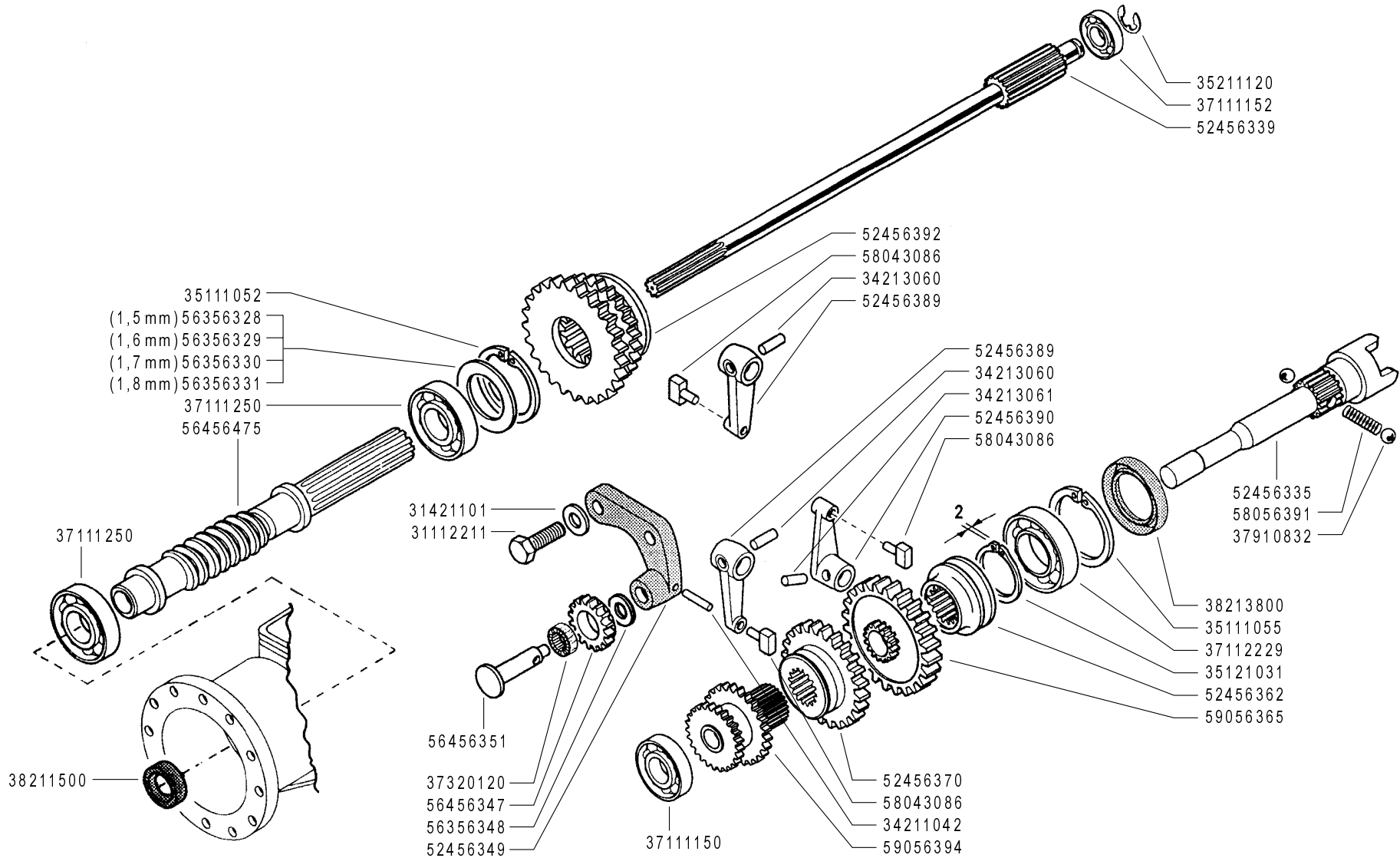

FERRARI

500 serie **GRIFON**

**INGRANAGGI CAMBIO
(515L GR - 515S GR - 515SL GR ★)**

GEARS
ENGRANAJES

ENGRANAGES
ZÄHNRÄDER

DALLA MACCHINA
DE LA MAQUINA
DE LA MACHINE
FROM THE MACHINE
AB DER MASCHINE

★N.

AGGIORNAMENTO
REVISION
MISE A JOUR
APLAZAMIENTO
ANPASSUNG

F02

Rev.
2

02/2009

ZENNE

Pos.	Code	Q.ty	Description	Notes
31112211	31112211	1	SCREW TE M10X30 UNI 5739	
31421101	31421101	1	WASHER	
34211042	34211042	1	ROLL PIN	
34213060	34213060	1	ROLL PIN	
34213061	34213061	1	ROLL PIN	
35111052	35111052	1	SEEGER RING	
35111055	35111055	1	SEEGER RING	
35121031	35121031	1	SEEGER RING	
35211120	35211120	1	SEEGER RING	
37111150	37111150	1	BEARING	
37111152	37111152	1	BEARING	
37111250	37111250	1	BEARING	
37112229	37112229	1	BEARING	
37320120	37320120	1	ROLLER CAGE 12X15/10	
37910832	37910832	1	BALL 1/4	
38211500	38211500	1	OIL SEAL 15X28X7	
38213800	38213800	1	OIL SEAL 38X55X7	
52456335	52456335	1	PTO SHAFT	
52456339	52456339	1	SHAFT	
52456349	52456349	1	GEAR SUPPORT	
52456362	52456362	1	COUPLING	
52456370	52456370	1	SLIDER	
52456389	52456389	1	LEVER	
52456390	52456390	1	LEVER	
52456392	52456392	1	SLIDER	
56356328	56356328	1	ADJUSTING RING SP=1,5	
56356329	56356329	1	ADJUSTING RING SP=1,6	
56356330	56356330	1	ADJUSTING RING SP=1,7	
56356331	56356331	1	ADJUSTING RING SP=1,8	
56356348	56356348	1	ADJUSTING RING	
56456347	56456347	1	GEAR	
56456351	56456351	1	GEAR PIN	
56456475	56456475	1	SCREW	
58043086	58043086	1	SHOE	

SERIAL

GEARS

CODE REV

F02_2_67738

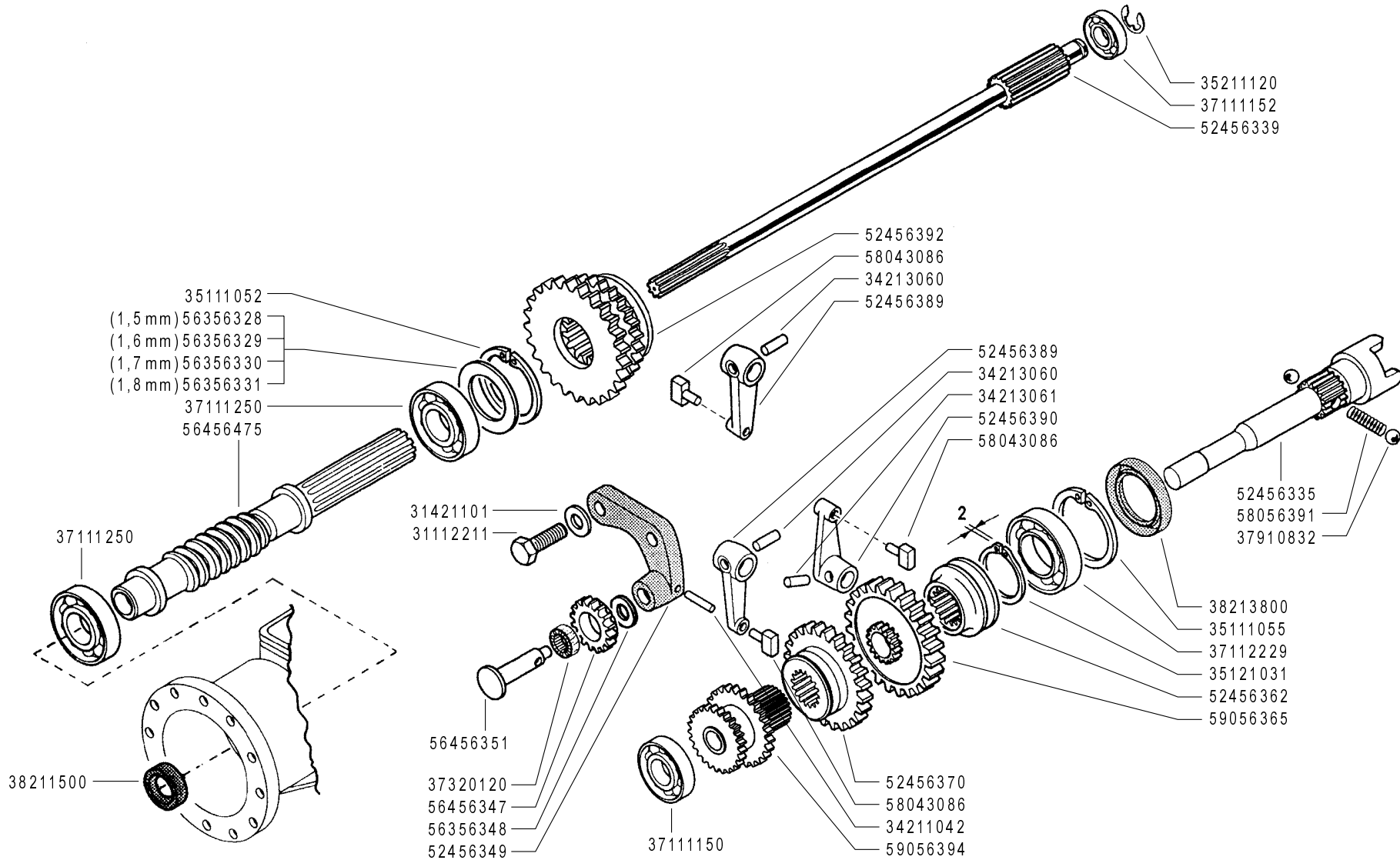

FERRARI

500 serie GRIFON

**INGRANAGGI CAMBIO
(515L GR - 515S GR - 515SL GR ★)**

GEARS
ENGRANAJES

ENGRANAGES
ZÄHNRÄDER

DALLA MACCHINA
DE LA MAQUINA
DE LA MACHINE
FROM THE MACHINE
AB DER MASCHINE

★N.

AGGIORNAMENTO
REVISION
MISE A JOUR
APLAZAMIENTO
ANPASSUNG

F02

02/2009

Rev.
2

ZENNE

Pos.	Code	Q.ty	Description	Notes
58056391	58056391	1	SPRING	
59056365	59056365	1	PTO GEAR	
59056394	59056394	1	DOUBLE GEAR	

GEARS

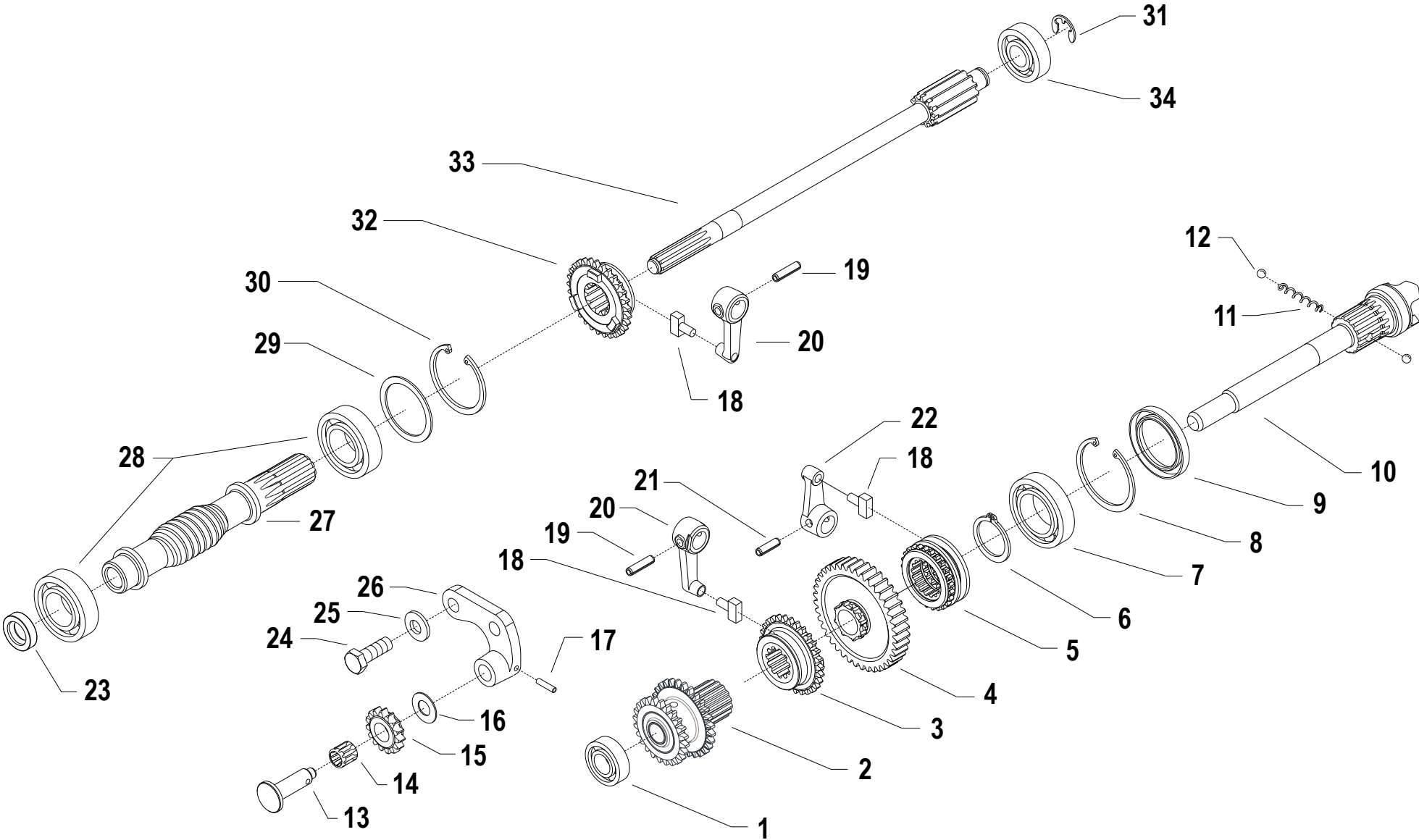

Pos.	Code	Q.ty	Description	Notes
1	37111150		BEARING	
2	59056394		DOUBLE GEAR	
3	52456370		SLIDER	
4	59056707		PTO GEAR	Replaces 59056365 + 52456362
5	52456706		PTO COUPLING	Replaces 59056365 + 52456362
6	35121031		SEEGER RING	
7	37112229		BEARING	
8	35111055		SEEGER RING	
9	38213800		OIL SEAL 38X55X7	
10	52456335		PTO SHAFT	
11	58056391		SPRING	
12	37910832		BALL 1/4	
13	56456736		GEAR PIN	Replaces 56456351
14	37320120		ROLLER CAGE 12X15/10	
15	56456347		GEAR	
16	56356348		ADJUSTING RING	
17	34211042		ROLL PIN	
18	58043086		SHOE	
19	34213060		ROLL PIN	
20	52456389		LEVER	
21	34213061		ROLL PIN	
22	52456390		LEVER	
23	38211500		OIL SEAL 15X28X7	
24	31112211		SCREW TE M10X30 UNI 5739	
25	31421101		WASHER	
26	52456349		GEAR SUPPORT	
27	56456475		SCREW	
28	37111255		BEARING	
29	56356328		ADJUSTING RING SP=1,5	
29	56356329		ADJUSTING RING SP=1,6	
29	56356330		ADJUSTING RING SP=1,7	
29	56356331		ADJUSTING RING SP=1,8	
30	35111052		SEEGER RING	
31	35211120		SEEGER RING	

SERIAL
START
937702

GEARS

CODE REV

F.02.02.A0011_03

GEARS

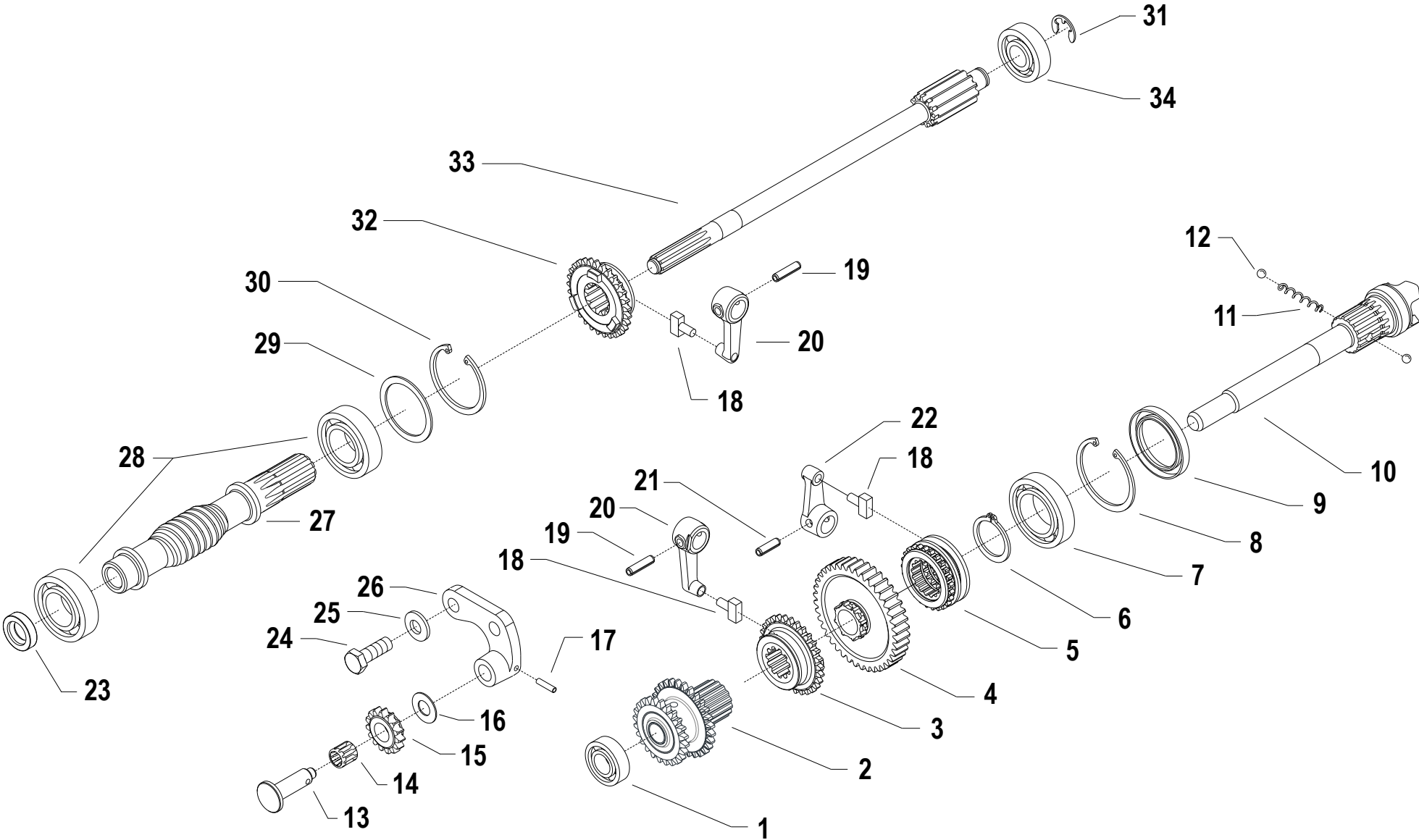

Pos.	Code	Q.ty	Description	Notes
32	52456392		SLIDER	
33	52456339		SHAFT	
34	37111152		BEARING	

SERIAL
START
937702

GEARS

CODE REV
F.02.02.A0011_03

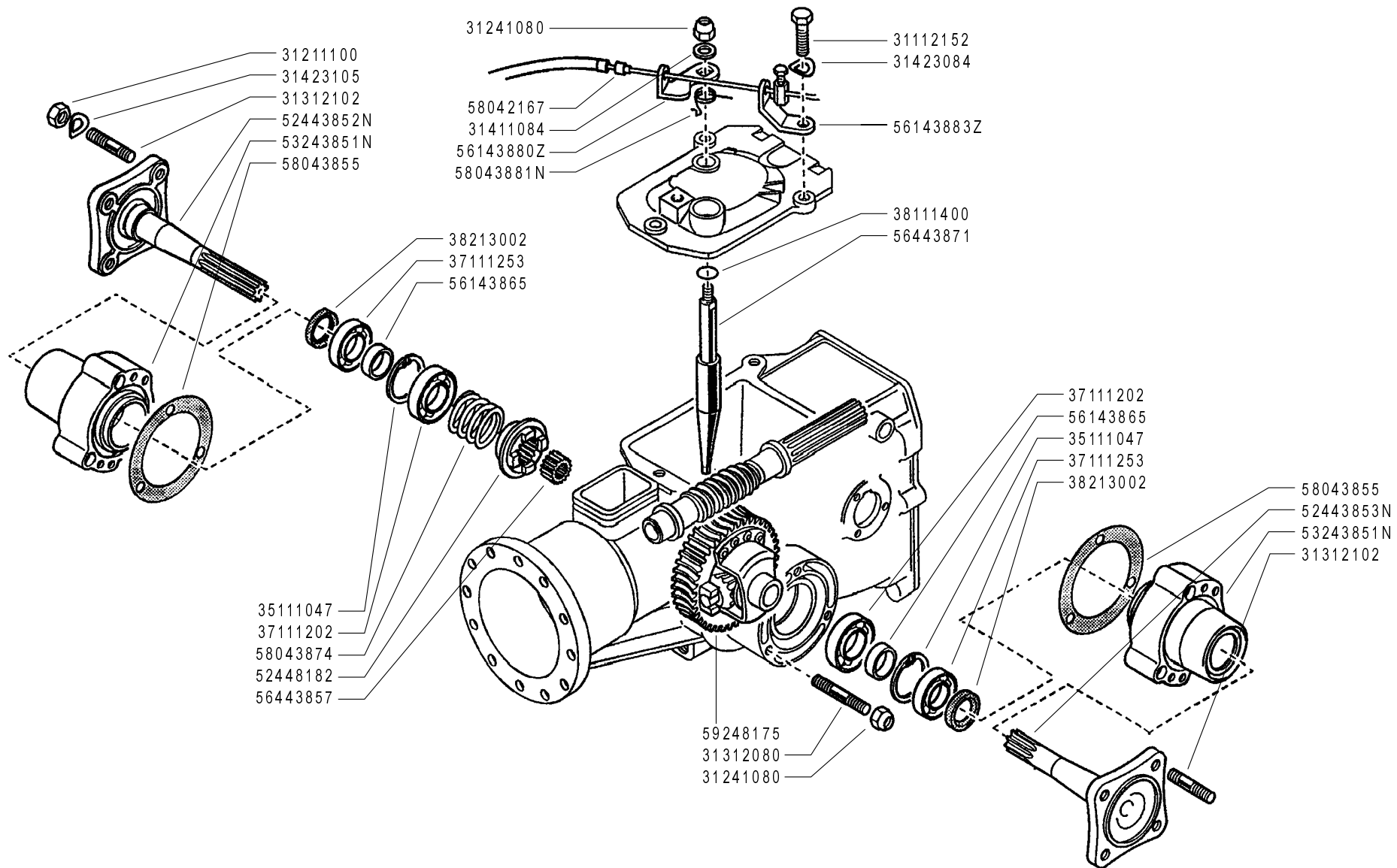

FERRARI

500 serie GRIFON

**DIFFERENZIALE
(515SL GR)**

DIFFERENTIAL
DIFFERENCIAL

DIFFÉRENTIEL
DIFFERENTIAL

DALLA MACCHINA
DE LA MAQUINA
DE LA MACHINE
FROM THE MACHINE
AB DER MASCHINE

N.

G05 0

02/2009

Rev.

ZENNE

Pos.	Code	Q.ty	Description	Notes
31112152	31112152	1	SCREW TE M8X30 UNI 5739 8G	
31211100	31211100	1	NUT M10	
31241080	31241080	1	HEXAGON SELFLOCK NUT M8	
31312080	31312080	1	STUD BOLT M8X46X20X12	
31312102	31312102	1	STUD BOLT M10X40X24X12	
31411084	31411084	1	WASHER 8,4x17	
31423084	31423084	1	SPRING WASHER 8,4	
31423105	31423105	1	SPRING WASHER 10,5	
35111047	35111047	1	SEEGER RING	
37111202	37111202	1	BEARING	
37111253	37111253	1	BEARING	
38111400	38111400	1	O-RING	
38213002	38213002	1	OIL SEAL 30X40X7	
52448182	52448182	1	COUPLING	
56143865	56143865	1	RING	
56443857	56443857	1	SPACER	
56443871	56443871	1	ROD	
58042167	58042167	1	SHEATH TERMINAL	
58043855	58043855	1	GASKET	
58043874	58043874	1	SPRING	
59248175	59248175	1	DIFFERENTIAL GEAR	
52443852	52443852N	1	AXLE SHAFT	
52443853	52443853N	1	AXLE SHAFT	
53243851	53243851N	1	HUB	
56143880	56143880Z	1	SMALL LEVER	
56143883	56143883Z	1	STOP	
58043881	58043881N	1	SPRING	

DIFFERENTIAL

SERIAL START 848877

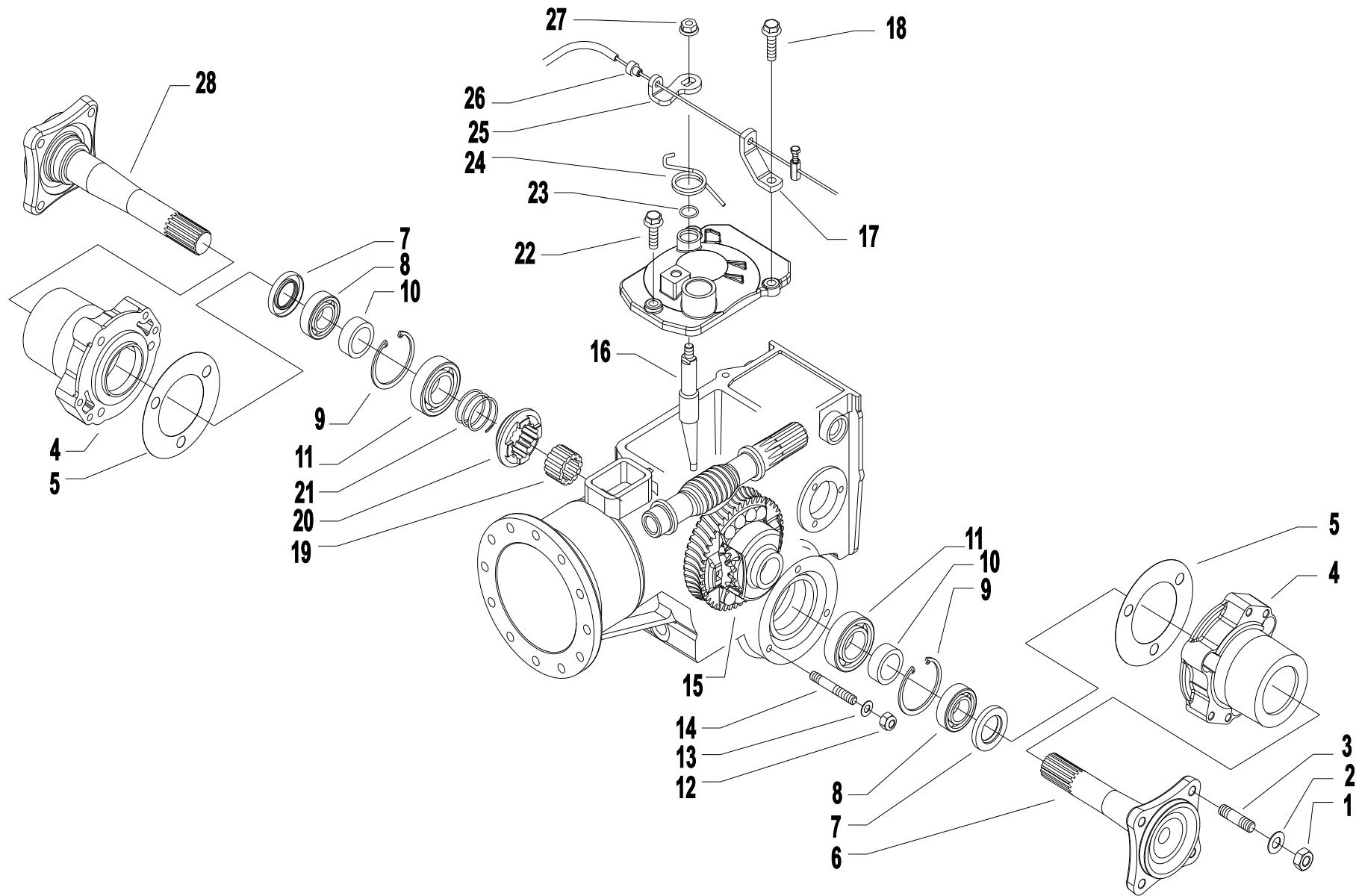

Pos.	Code	Q.ty	Description	Notes
1	31211100	1	NUT M10	
2	31423105	1	SPRING WASHER 10,5	
3	31312102	1	STUD BOLT M10X40X24X12	
4	53243851N	1	HUB	
5	58043855	1	GASKET	
6	52448187	1	AXLE SHAFT	
7	38213002	1	OIL SEAL 30X40X7	
8	37111253	1	BEARING	
9	35111047	1	SEEGER RING	
10	56148184	1	RING	
11	37111250	1	BEARING	
12	31241080	1	HEXAGON SELFLOCK NUT M8	
13	31423084	1	SPRING WASHER 8,4	
14	31312080	1	STUD BOLT M8X46X20X12	
15	59048181	1	DIFFERENTIAL GEAR	
16	56443871	1	ROD	
17	56143883Z	1	STOP	
18	31112167	1	SCREW TE C/F M8X30 DIN 6921 8G	
19	56448183	1	SPACER	
20	56448196	1	COUPLING	
21	58043874	1	SPRING	
22	31112166	1	SCREW TE C/F M8X25 DIN 6921 8G	
23	38111400	1	O-RING	
24	58043881N	1	SPRING	
25	56143880Z	1	SMALL LEVER	
26	58042167	1	SHEATH TERMINAL	
27	31241084	1	SELFLOCK NUT M8 6S	
28	52448188N	1	AXLE SHAFT	

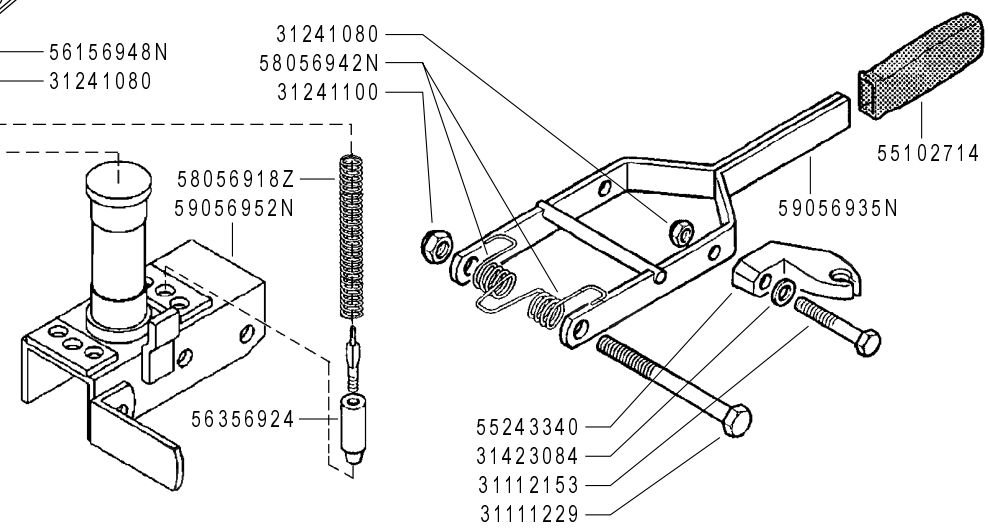
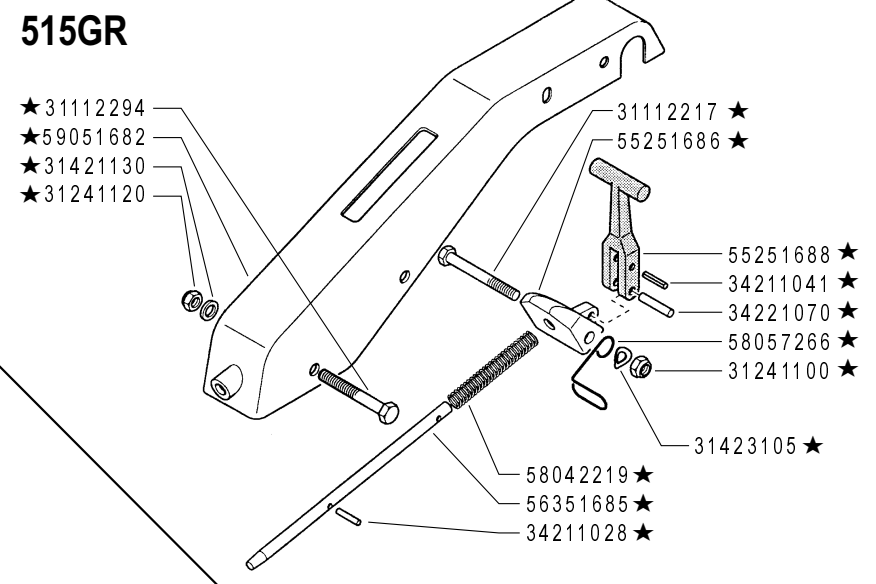
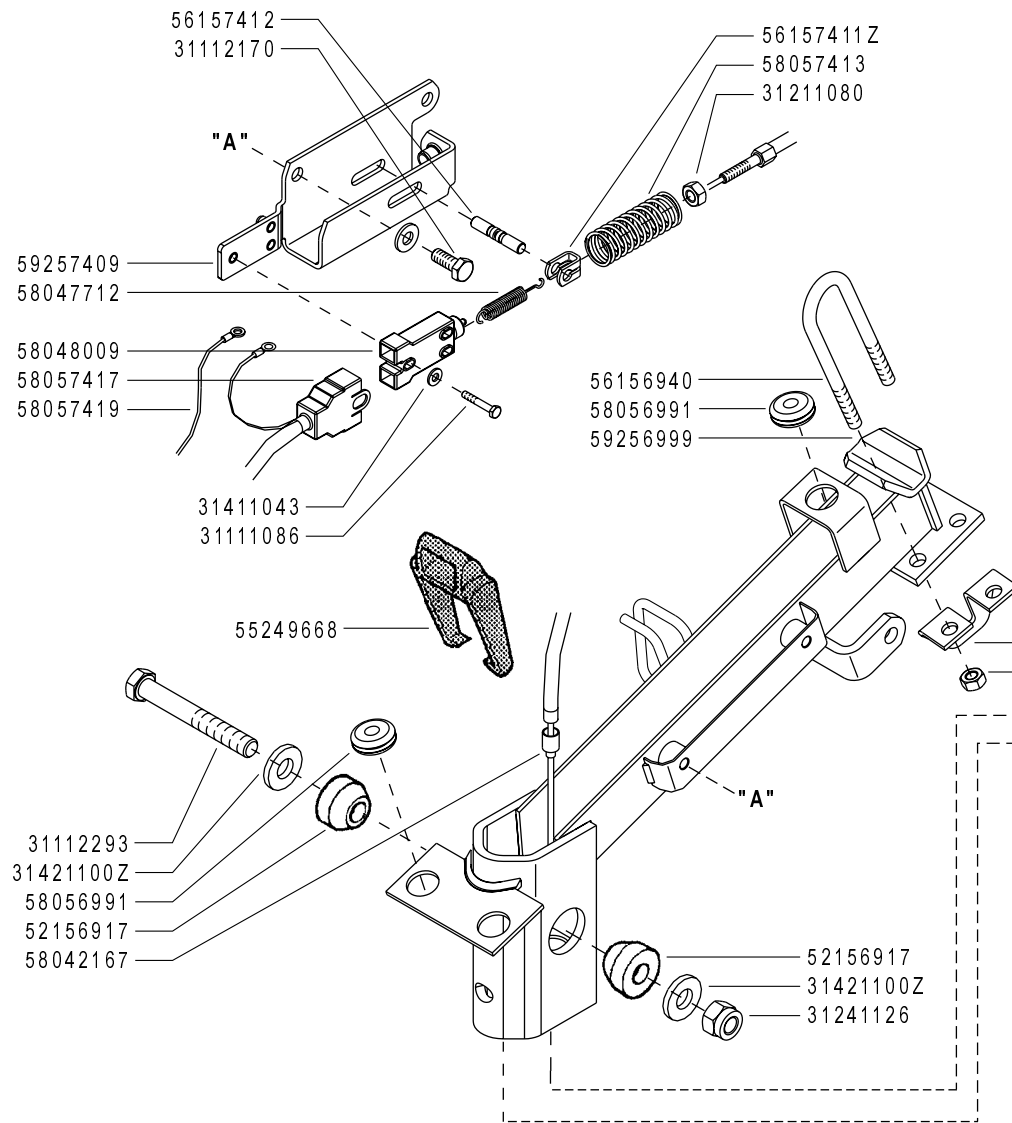

FERRARI 500 serie GRIFON

PIANTONE
(515GR - 515L GR - 515S GR - 515SL GR ★)

STEERING COLUMN
COLUMNNA

PLANTON
LENKSÄULE

DALLA MACCHINA
DE LA MAQUINA
FROM THE MACHINE
AB DER MASCHINE

★N.

ERRATA CORRIGE
825532 (515GR)

Rev.	2
H01	02/2009

Pos.	Code	Q.ty	Description	Notes
31111086	31111086	1	SCREW TE M4X25 UNI 5739 8G	
31111229	31111229	1	SCREW TE M10X110 UNI 5737 8G	
31112153	31112153	1	SCREW TE M8X35 UNI 5739 8G	
31112170	31112170	1	SCREW TE C/F M8X20 DIN 6921	
31112217	31112217	1	SCREW TE M10X80 UNI 5737	
31112293	31112293	1	SCREW TE M12X80 UNI 5737	
31112294	31112294	1	SCREW TE M12X85 UNI 5737	
31211080	31211080	1	NUT M8	
31241080	31241080	1	HEXAGON SELFLOCK NUT M8	
31241100	31241100	1	SELFLOCK HEXAGON NUT M10	
31241120	31241120	1	SELFLOCK NUT M12	
31241126	31241126	1	SELFLOCK NUT M12	
31411043	31411043	1	WASHER 4,3X9	
31421130	31421130	1	WASHER	
31423084	31423084	1	SPRING WASHER 8,4	
31423105	31423105	1	SPRING WASHER 10,5	
34211028	34211028	1	ROLL PIN	
34211041	34211041	1	ROLL PIN	
34221070	34221070	1	CYLINDRICAL PLUG 8X50 UNI 1707	
52156917	52156917	1	WEDGE	
55102714	55102714	1	KNOB	
55243340	55243340	1	SUPPORT	
55249668	55249668	1	PASSING	
55251686	55251686	1	LEVER BEARING	
55251688	55251688	1	LEVER	
56156940	56156940	1	U BOLT	
56157412	56157412	1	PIN	
56351685	56351685	1	ROD	
56356924	56356924	1	FERRULE	
58042167	58042167	1	SHEATH TERMINAL	
58042219	58042219	1	SPRING	
58047712	58047712	1	SPRING	
58048009	58048009	1	SWITCH	
58056991	58056991	1	CABLE GLAND	

SERIAL
START
825532

STEERING COLUMN

Version: 515GR, 515L GR, 515S GR, 515SL GR

CODE REV

H01_2_67804

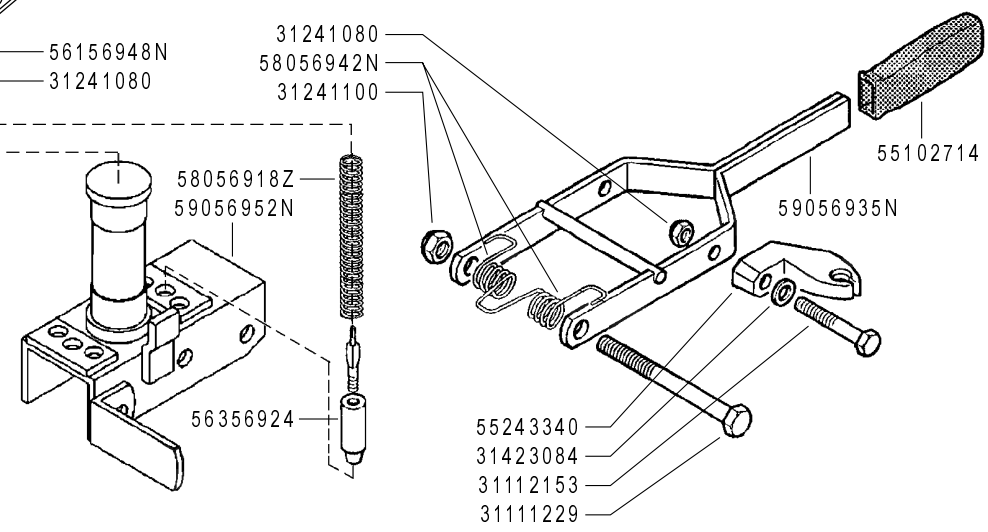
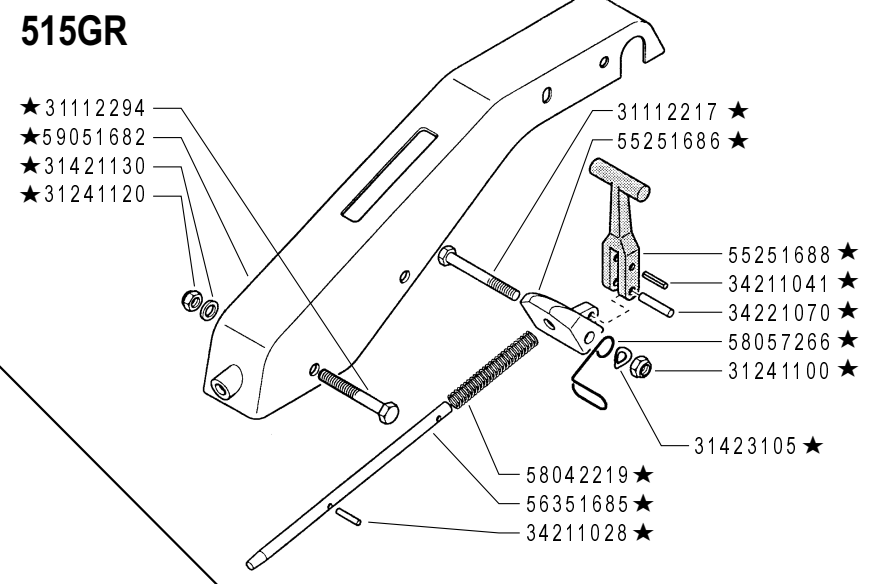
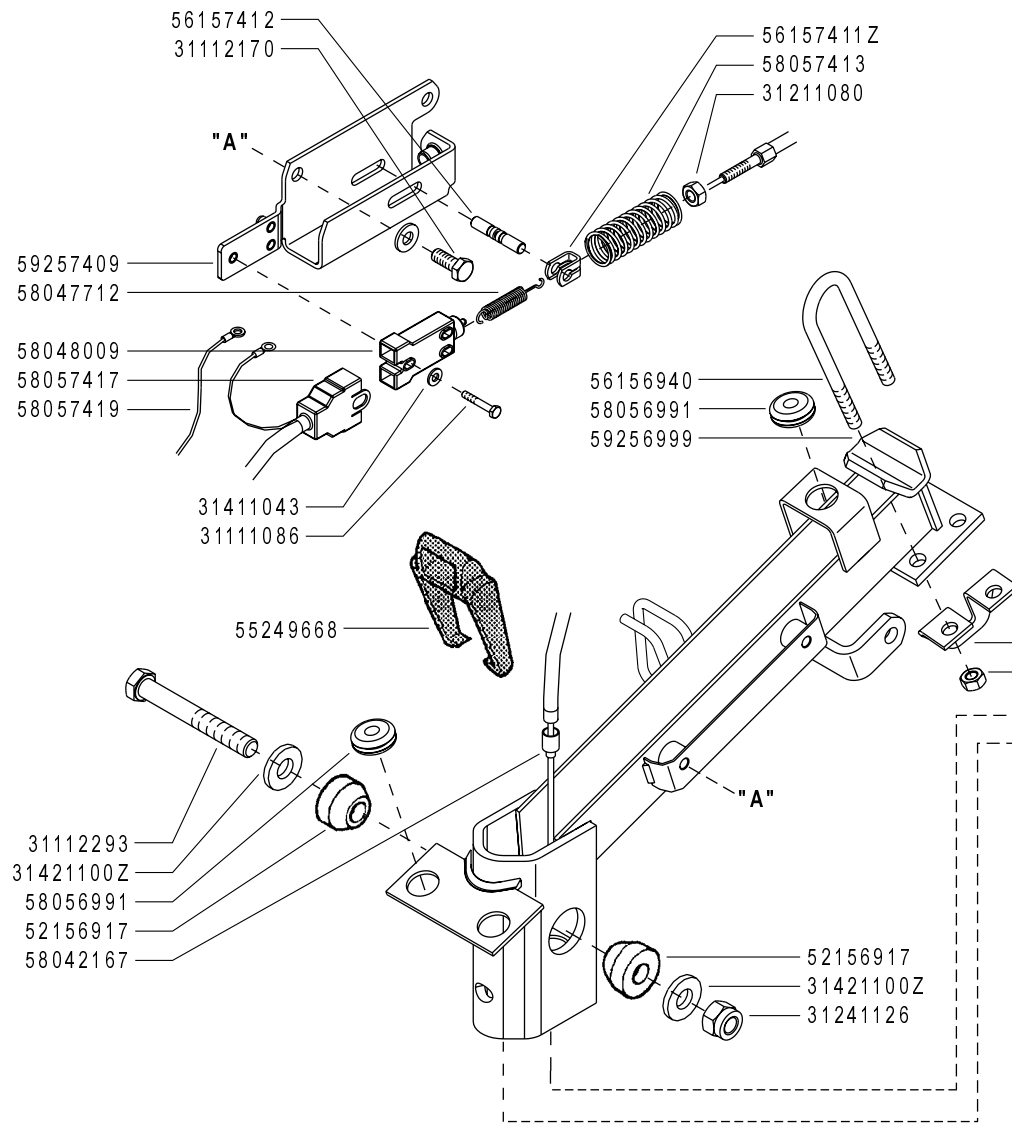

	500 serie GRIFON	PIANTONE (515GR - 515L GR - 515S GR - 515SL GR ★)		DALLA MACCHINA DE LA MAQUINA FROM THE MACHINE AB DER MASCHINE	ERRATA CORRIGE	Rev. H01 2
		STEERING COLUMN COLUMNNA	PLANTON LENKSÄULE		★N.	

Pos.	Code	Q.ty	Description	Notes
58057266	58057266	1	HOLDER	
58057413	58057413	1	RETAINING SPRING	
58057417	58057417	1	WIRING	
58057419	58057419	1	WIRING	
59051682	59051682	1	HANDLE BAR COLUMN	
59256999	59256999	1	COLUMN	
59257409	59257409	1	SUPPORT	
31421100	31421100Z	1	CUP SPRING	
56156948	56156948N	1	STOP	
56157411	56157411Z	1	FORK	
58056918	58056918Z	1	SPRING	
58056942	58056942N	1	SPRING	
59056935	59056935N	1	LEVER	
59056952	59056952N	1	SUPPORT	

SERIAL
START
825532

STEERING COLUMN

Version: 515GR, 515L GR, 515S GR, 515SL GR

CODE REV

H01_2_67804

STEERING COLUMN

SERIAL START 863996

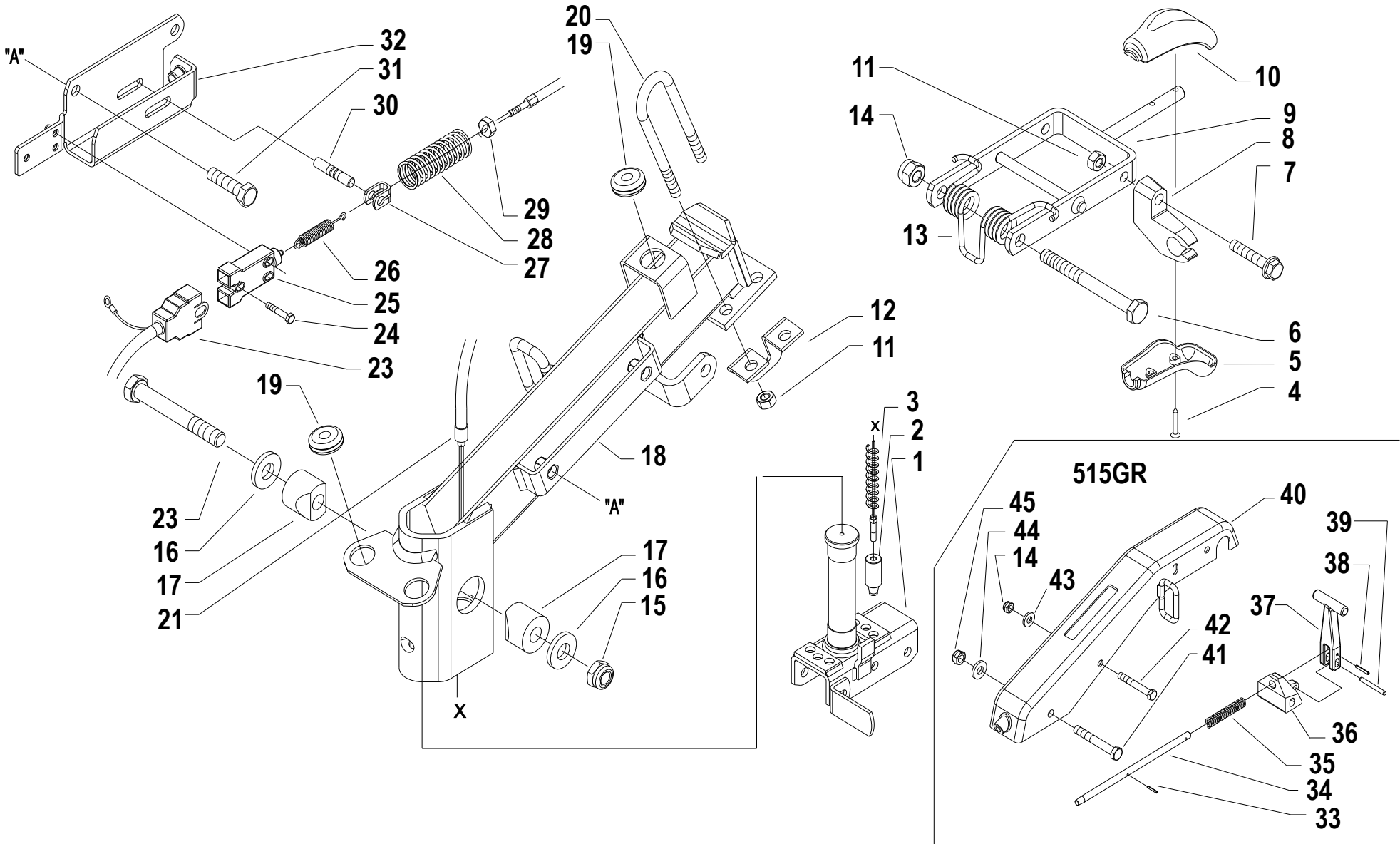

Pos.	Code	Q.ty	Description	Notes
1	59056952N	1	SUPPORT	
2	56356924	1	FERRULE	
3	58056918Z	1	SPRING	
4	31100451	1	SCREW 3,5X25	
5	55157213	1	GRIP	
6	31111229	1	SCREW TE M10X110 UNI 5737 8G	
7	31112165	1	SCREW TE C/F M8X35 DIN 6921 8G	
8	55243340	1	SUPPORT	
9	59057010N	1	LEVER	
10	55157212	1	GRIP	
11	31241080	1	HEXAGON SELFLOCK NUT M8	
12	56156948N	1	STOP	
13	58056942N	1	SPRING	
14	31241100	1	SELFLOCK HEXAGON NUT M10	
15	31241126	1	SELFLOCK NUT M12	
16	31421100Z	1	CUP SPRING	
17	52156917	1	WEDGE	
18	59256999	1	COLUMN	
19	58056991	1	CABLE GLAND	
20	56156940	1	U BOLT	
21	58042167	1	SHEATH TERMINAL	
22	31112293	1	SCREW TE M12X80 UNI 5737	
23	58057417	1	WIRING	
24	31121024	1	SCREW TBCEI FL.M4X25	
25	58048009	1	SWITCH	
26	58047712	1	SPRING	
27	56157411Z	1	FORK	
28	58057413	1	RETAINING SPRING	
29	31211080	1	NUT M8	
30	56157412	1	PIN	
31	31112170	1	SCREW TE C/F M8X20 DIN 6921	
32	59257409	1	SUPPORT	
33	34211028	1	ROLL PIN	
34	56351685Z	1	ROD	

SERIAL
START
863996

STEERING COLUMN

CODE REV

H.01.02.A0011_03

STEERING COLUMN

SERIAL START 863996

H.01.02.A0011_03

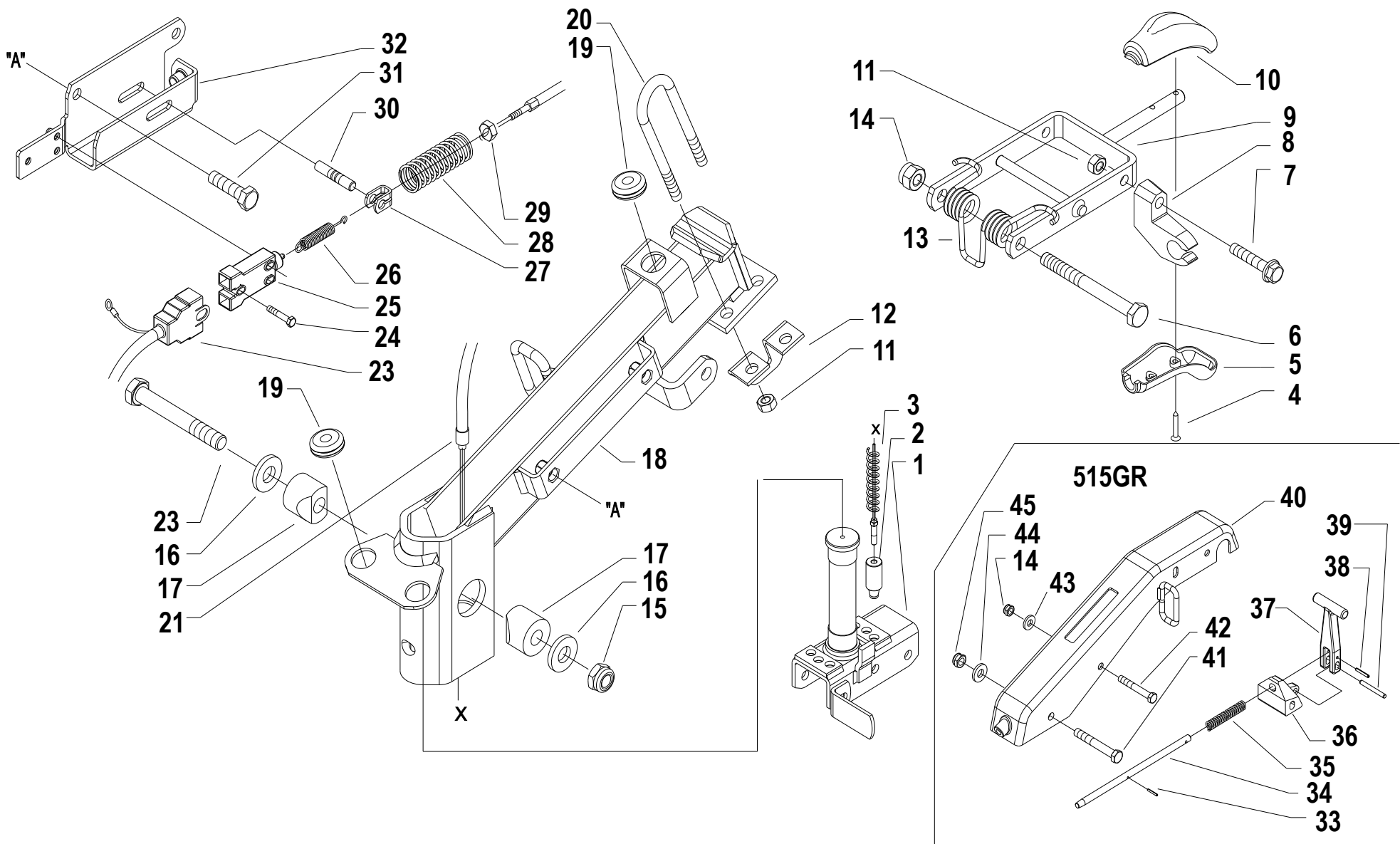

Pos.	Code	Q.ty	Description	Notes
35	58042219	1	SPRING	
36	55251686	1	LEVER BEARING	
37	55251688	1	LEVER	
38	34211041	1	ROLL PIN	
39	34221070	1	CYLINDRICAL PLUG 8X50 UNI 1707	
40	59056817V	1	COLUMN	
41	31112294	1	SCREW TE M12X85 UNI 5737	
42	31112217	1	SCREW TE M10X80 UNI 5737	
43	31423105	1	SPRING WASHER 10,5	
44	31421130	1	WASHER	
45	31241120	1	SELFLOCK NUT M12	

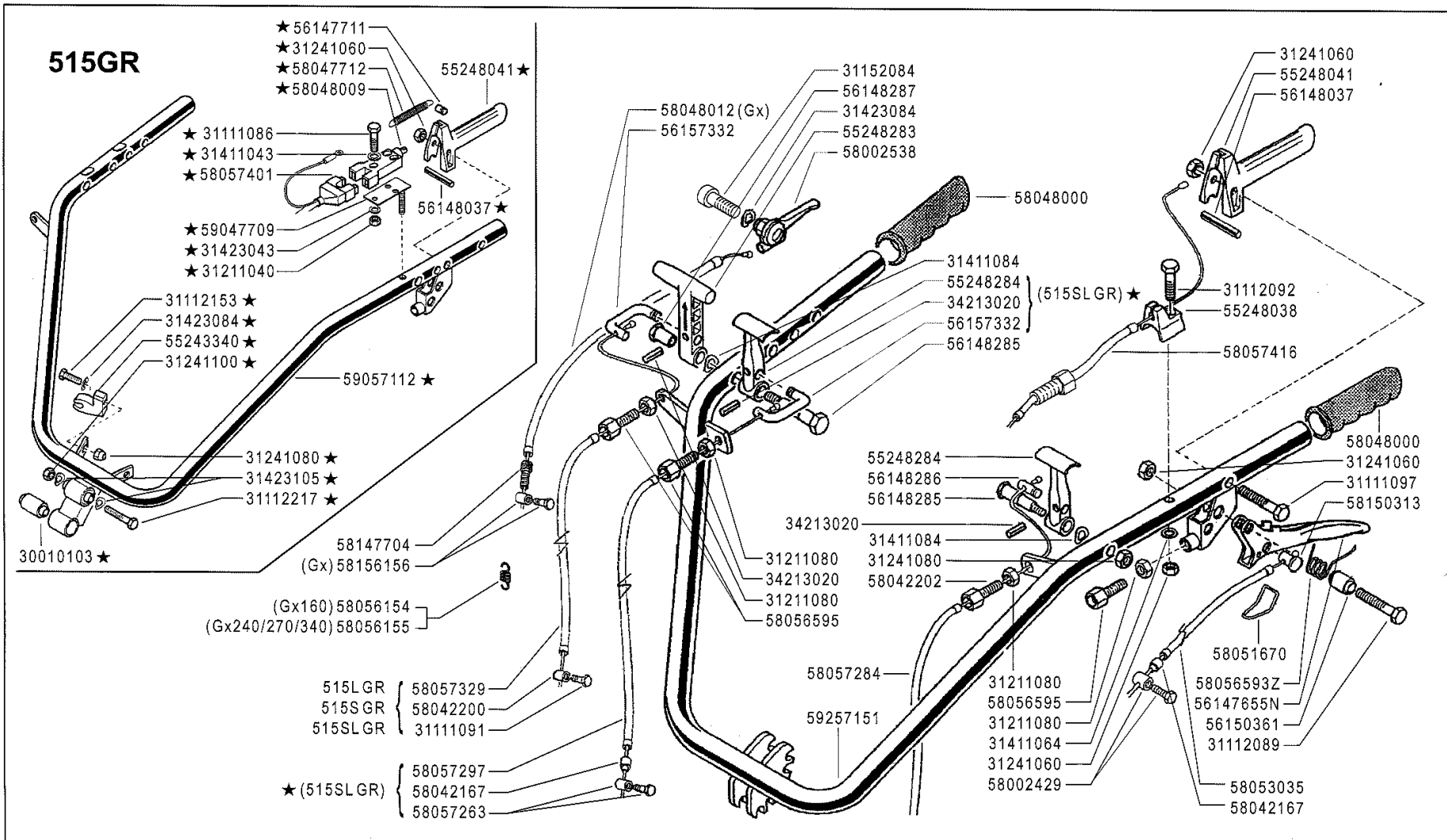

FERRARI

500 serie GRIFON

MANUBRIO
(515GR - 515LGR - 515SGR - 515SLGR ★)

ENGINE GUARDS
PROTECCIONES MOTOR

PROTECTIONS MOTEUR
MOTOR SCHUTZ

DALLA MACCHINA
DE LA MAQUINA
DE LA MACHINE
FROM THE MACHINE
AB DER MASCHINE

ERRATA CORRIGE

★ N.

825532 (515GR)

I01

Rev.
2

02/2009

ZENNE

Pos.	Code	Q.ty	Description	Notes
30010103	30010103	1	SILENT-BLOCK 10,2X30X45X60,5	
31111086	31111086	1	SCREW TE M4X25 UNI 5739 8G	
31111091	31111091	1	SCREW E M6X14 UNI 5739 8G	
31111097	31111097	1	SCREW TE M6X45 UNI 5737 8G	
31112089	31112089	1	SCREW TE M6X25 UNI 5739 8G	
31112092	31112092	1	SCREW TE M6X35 UNI 5739 8G	
31112153	31112153	1	SCREW TE M8X35 UNI 5739 8G	
31112217	31112217	1	SCREW TE M10X80 UNI 5737	
31152084	31152084	1	SCREW TCEI M8X35 UNI 5931	
31211040	31211040	1	NUT M4	
31211080	31211080	1	NUT M8	
31241060	31241060	1	HEXAGON SELFLOCK NUT M6	
31241080	31241080	1	HEXAGON SELFLOCK NUT M8	
31241100	31241100	1	SELFLOCK HEXAGON NUT M10	
31411043	31411043	1	WASHER 4,3X9	
31411064	31411064	1	WASHER 6,4x12,5	
31411084	31411084	1	WASHER 8,4x17	
31423043	31423043	1	SPRING WASHER 4,3	
31423084	31423084	1	SPRING WASHER 8,4	
31423105	31423105	1	SPRING WASHER 10,5	
34213020	34213020	1	ROLL PIN	
55243340	55243340	1	SUPPORT	
55248038	55248038	1	STOP	
55248041	55248041	1	LEVER	
55248283	55248283	1	COMMAND LEVER	
55248284	55248284	1	LEVER	
56147711	56147711	1	PIN	
56148037	56148037	1	LEVER STOP	
56148285	56148285	1	PIN	
56148286	56148286	1	PIN	
56150361	56150361	1	SPACER	
56157332	56157332	1	U BOLT	
58002429	58002429	1	CLAMPING SCREW	
58042167	58042167	1	SHEATH TERMINAL	

SERIAL
START
825532

HANDLEBAR

Version: 515GR, 515L GR, 515S GR, 515SL GR

CODE REV

I01_2_67839

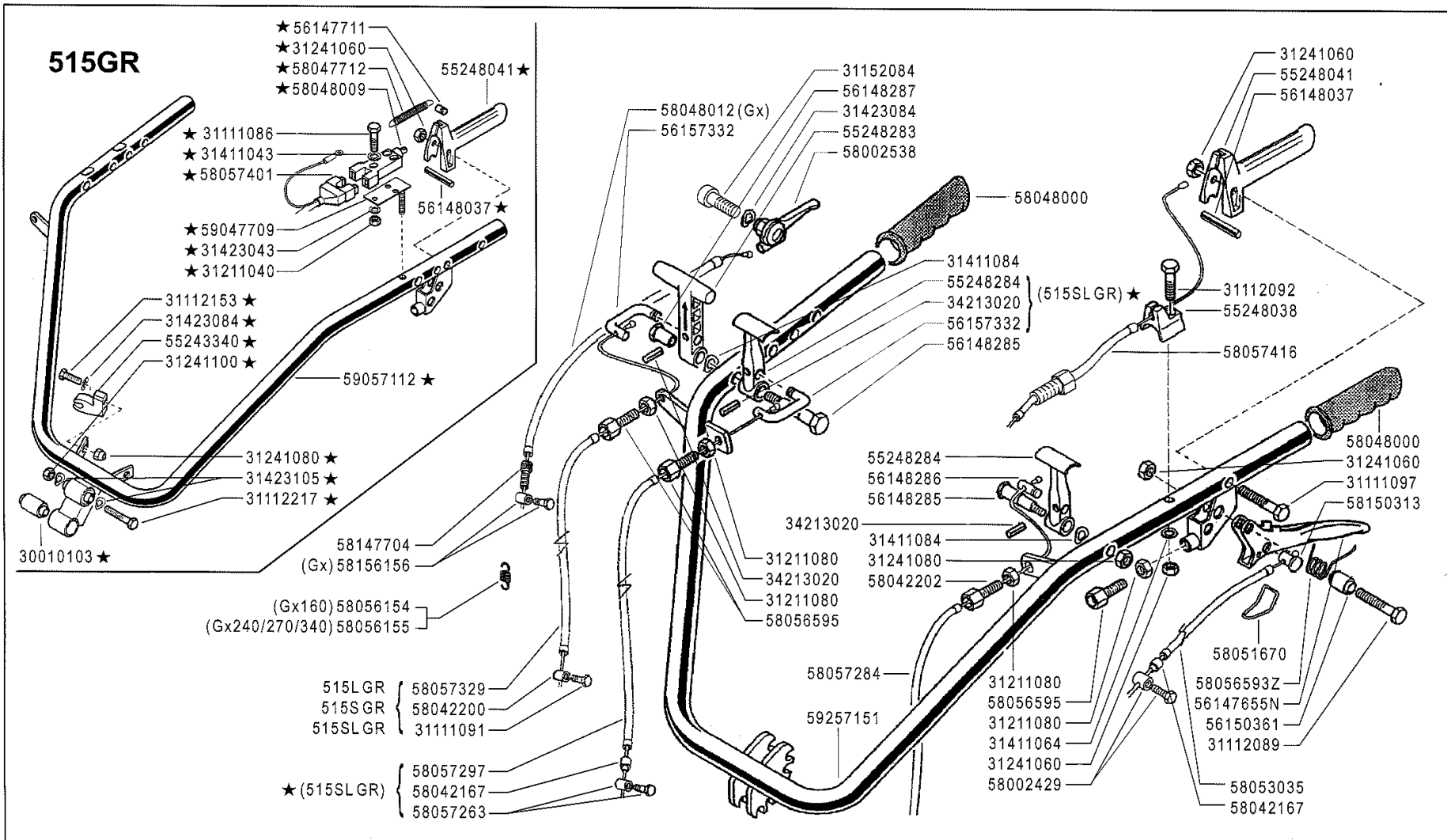

FERRARI

500 serie **GRIFON**

MANUBRIO
(515GR - 515LGR - 515SGR - 515SLGR ★)

ENGINE GUARDS
PROTECCIONES MOTOR

PROTECTIONS MOTEUR
MOTOR SCHUTZ

DALLA MACCHINA
DE LA MAQUINA
DE LA MACHINE
FROM THE MACHINE
AB DER MASCHINE

ERRATA CORRIGE

★ N.

825532 (515GR)

I01

Rev.
2

02/2009

ZENNE

Pos.	Code	Q.ty	Description	Notes
58042200	58042200	1	CLAMPING SCREW	
58042202	58042202	1	ADJUSTING SCREW	
58047712	58047712	1	SPRING	
58048000	58048000	1	KNOB	
58048009	58048009	1	SWITCH	
58048012	58048012	1	LINE AND SHEATH	
58051670	58051670	1	CLEVIS	
58053035	58053035	1	LINE AND SHEATH	
58056154	58056154	1	RESTORING SPRING	Utilizzato con motore GX200
58056155	58056155	1	RESTORING SPRING	Utilizzato con motore GX270
58056158	58056158	1	COUPLING	
58056164	58056164	1	RESTORING SPRING	
58056595	58056595	1	ADJUSTING SCREW	
58057263	58057263	1	CLAMPING SCREW	
58057284	58057284	1	LINE AND SHEATH	
58057297	58057297	1	LINE AND SHEATH	
58057329	58057329	1	LINE AND SHEATH	
58057401	58057401	1	WIRING	
58057416	58057416	1	LINE AND SHEATH	
58147704	58147704	1	ADJUSTING SCREW	
58150313	58150313	1	CABLE CLAMP	
58156156	58156156	1	TERMINAL	
59047709	59047709	1	SWITCH SUPPORT	
59057112	59057112	1	COMPLETE HANDLE BAR	
59257151	59257151	1	COMPLETE HANDLE BAR	
56147655	56147655N	1	CLUTCH LEVER	
58056593	58056593Z	1	SPRING	

SERIAL
START
825532

HANDLEBAR

Version: 515GR, 515L GR, 515S GR, 515SL GR

CODE REV

I01_2_67839

HANDLEBAR

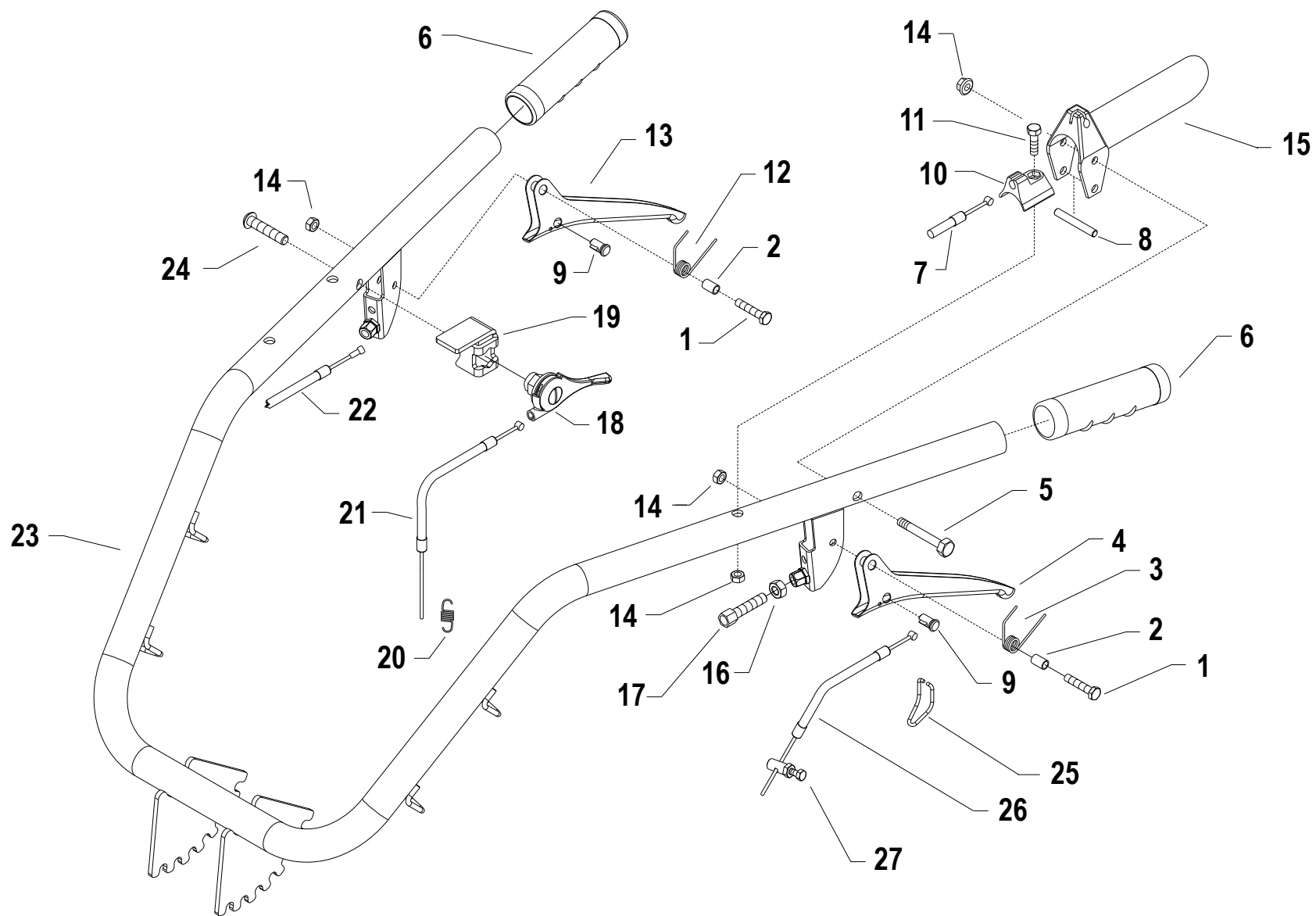

Pos.	Code	Q.ty	Description	Notes
1	31112089	1	SCREW TE M6X25 UNI 5739 8G	
2	56156603Z	1	SPACER	
3	58050345	1	SPRING	
4	56147655N	1	CLUTCH LEVER	
5	31111097	1	SCREW TE M6X45 UNI 5737 8G	
6	58048000	1	KNOB	
7	58048355	1	LINE AND SHEATH	For diesel engines
7	58057418	1	LINE AND SHEATH	
8	56148037	1	LEVER STOP	
9	58150313	1	CABLE CLAMP	
10	55248038	1	STOP	
11	31112092	1	SCREW TE M6X35 UNI 5739 8G	
12	58056593	1	SPRING	
13	56148470N	1	LEVER	
14	31241060	1	HEXAGON SELFLOCK NUT M6	
15	55248041	1	LEVER	
16	31211080	1	NUT M8	
17	58056595	1	ADJUSTING SCREW	
18	58002538	1	COMMAND LEVER	
19	56156874N	1	PANEL	
20	58056154	1	RESTORING SPRING	Utilizzato con motore GX200 - For motors GX200
20	58056155	1	RESTORING SPRING	Utilizzato con motore GX270 - For the engine GX270
21	58056815	1	LINE AND SHEATH	For motors GX200/GX270
22	58056193	1	COLUMN TRANSMISSION	
23	59257162	1	HANDLE BAR	
24	31121020	1	SCREW TBCEI M8X40 ISO7380 10K Z	
25	58051670	1	CLEVIS	
26	58053035	1	LINE AND SHEATH	ERRATA CORRIGE
27	58042200	1	CLAMPING SCREW	

HANDLEBAR

SERIAL START 953269

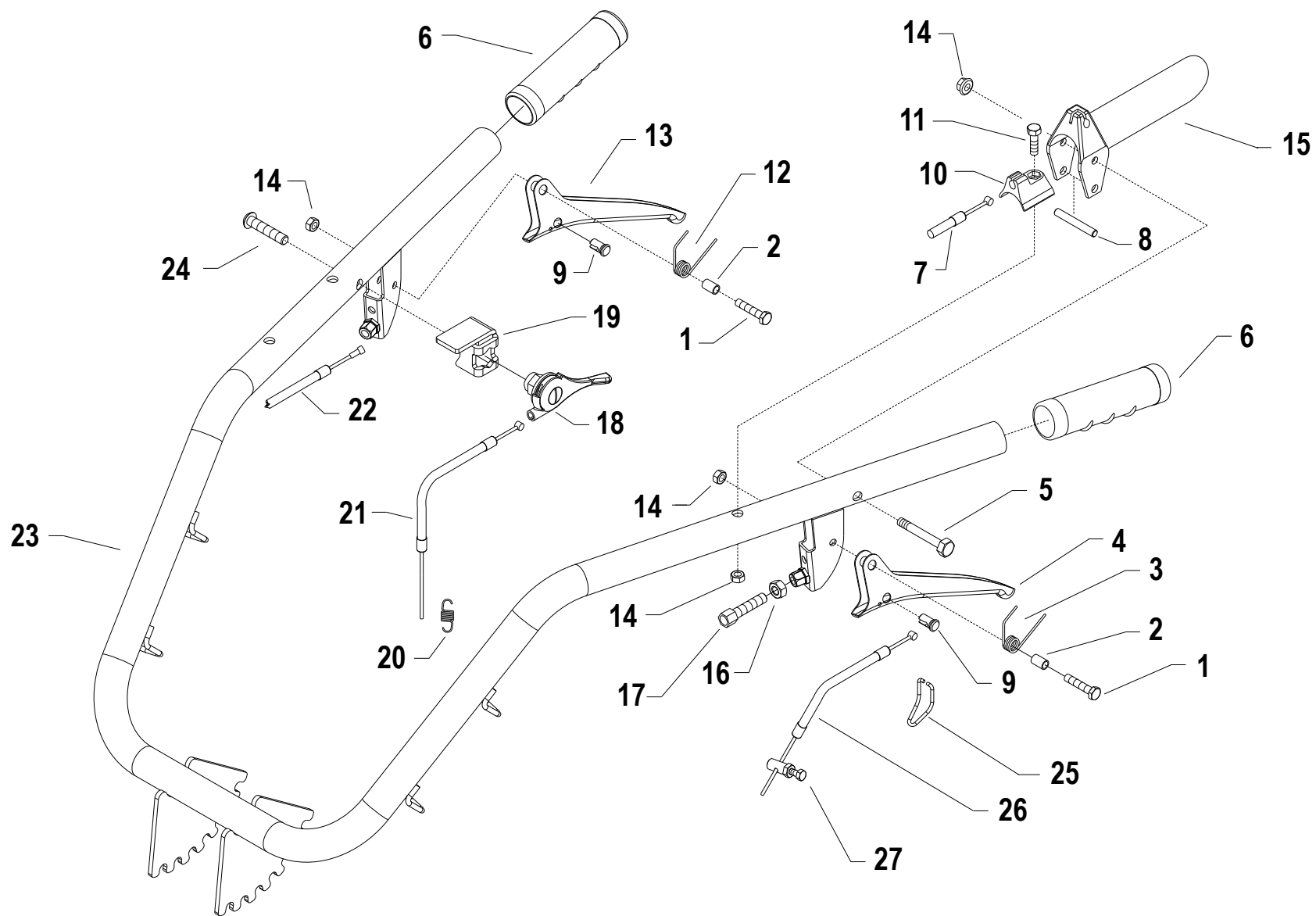

Pos.	Code	Q.ty	Description	Notes
5	31111097	1	SCREW TE M6X45 UNI 5737 8G	
1	31112089	1	SCREW TE M6X25 UNI 5739 8G	
11	31112092	1	SCREW TE M6X35 UNI 5739 8G	
24	31121020	1	SCREW TBCEI M8X40 ISO7380 10K Z	
16	31211080	1	NUT M8	
14	31241060	1	HEXAGON SELFLOCK NUT M6	
10	55248038	1	STOP	
15	55248041	1	LEVER	
4	56147655N	1	CLUTCH LEVER	
8	56148037	1	LEVER STOP	
13	56148470N	1	LEVER	
2	56156603Z	1	SPACER	
19	56156874N	1	PANEL	
18	58002538	1	COMMAND LEVER	
27	58042200	1	CLAMPING SCREW	
6	58048000	1	KNOB	
7	58048355	1	LINE AND SHEATH	DIESEL
3	58050345	1	SPRING	
25	58051670	1	CLEVIS	
20	58056154	1	RESTORING SPRING	Utilizzato con motore GX200 - GX200
20	58056155	1	RESTORING SPRING	Utilizzato con motore GX270 - GX270
22	58056193	1	COLUMN TRANSMISSION	
12	58056593	1	SPRING	
17	58056595	1	ADJUSTING SCREW	
21	58056815	1	LINE AND SHEATH	GX200/GX270
26	58057285	1	LINE AND SHEATH	
7	58057418	1	LINE AND SHEATH	
9	58150313	1	CABLE CLAMP	
23	59257162	1	HANDLE BAR	

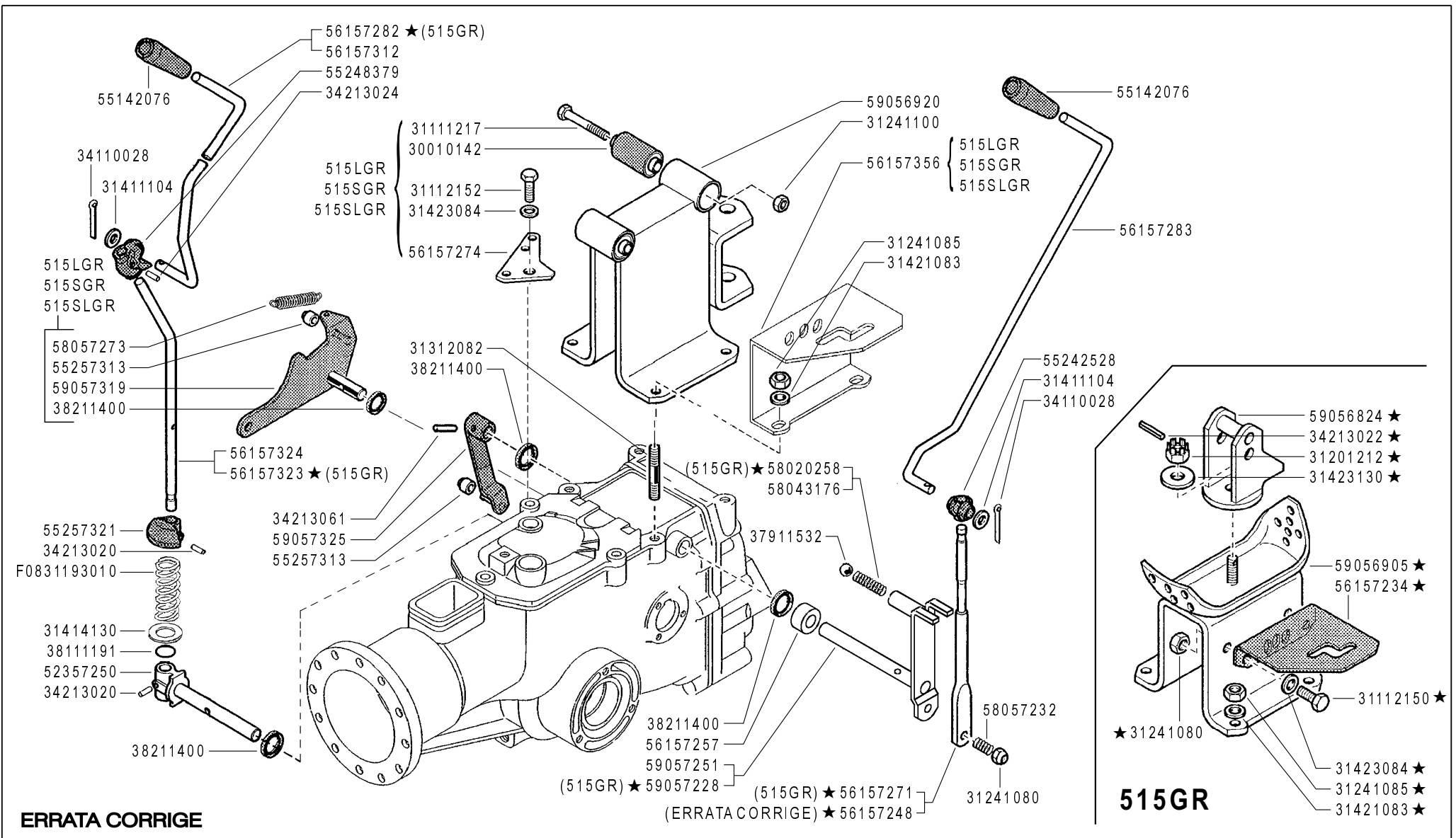

ERRATA CORRIGE

	500 serie GRIFON	COMANDI (515GR - 515L GR - 515S GR - 515SL GR ★)		DALLA MACCHINA DE LA MAQUINA DE LA MACHINE FROM THE MACHINE AB DER MASCHINE	<table border="1"> <tr><td> </td></tr> <tr><td> </td></tr> <tr><td> </td></tr> <tr><td> </td></tr> </table>					J01	Rev. 1
CONTROLS MANDOS	COMMANDES ANTRIEBE	★N.	825532 (515GR)	02/2009							

Pos.	Code	Q.ty	Description	Notes
30010142	30010142	1	SILENT-BLOCK 10,2X30X45X49	
31111217	31111217	1	SCREW TE M10X75 UNI 5737 8G	
31112150	31112150	1	SCREW TE M8X20 UNI 5739 8G	
31112152	31112152	1	SCREW TE M8X30 UNI 5739 8G	
31201212	31201212	1	NUT M12	
31241080	31241080	1	HEXAGON SELFLOCK NUT M8	
31241085	31241085	1	SELFLOCK NUT M8 6S	
31241100	31241100	1	SELFLOCK HEXAGON NUT M10	
31312082	31312082	1	STUD BOLT M8X38X14X20	
31411104	31411104	1	WASHER 10,5x18	
31414130	31414130	1	WASHER 13	
31421083	31421083	1	WASHER	
31423084	31423084	1	SPRING WASHER 8,4	
31423130	31423130	1	SPRING WASHER 13	
34110028	34110028	1	SPLIT PIN	
34213020	34213020	1	ROLL PIN	
34213022	34213022	1	ROLL PIN	
34213024	34213024	1	ROLL PIN	
34213061	34213061	1	ROLL PIN	
37911532	37911532	1	BALL 15/32	
38111191	38111191	1	O-RING	
38111400	38111400	1	O-RING	
38211400	38211400	1	OIL SEAL 14X22X4	
52357250	52357250	1	PIN	
55142076	55142076	1	KNOB	
55242528	55242528	1	JOINT	
55248379	55248379	1	JOINT	
55257313	55257313	1	ROLLER	
55257321	55257321	1	STOP	
56157234	56157234	1	GEAR SELECTOR	
56157248	56157248	1	COMMAND LEVER	
56157257	56157257	1	SPACER	
56157271	56157271	1	COMMAND LEVER	
56157274	56157274	1	SQUARE	

SERIAL
START
825532

CONTROLS

Version: 515GR, 515L GR, 515S GR, 515SL GR

CODE REV

J01_1_67885

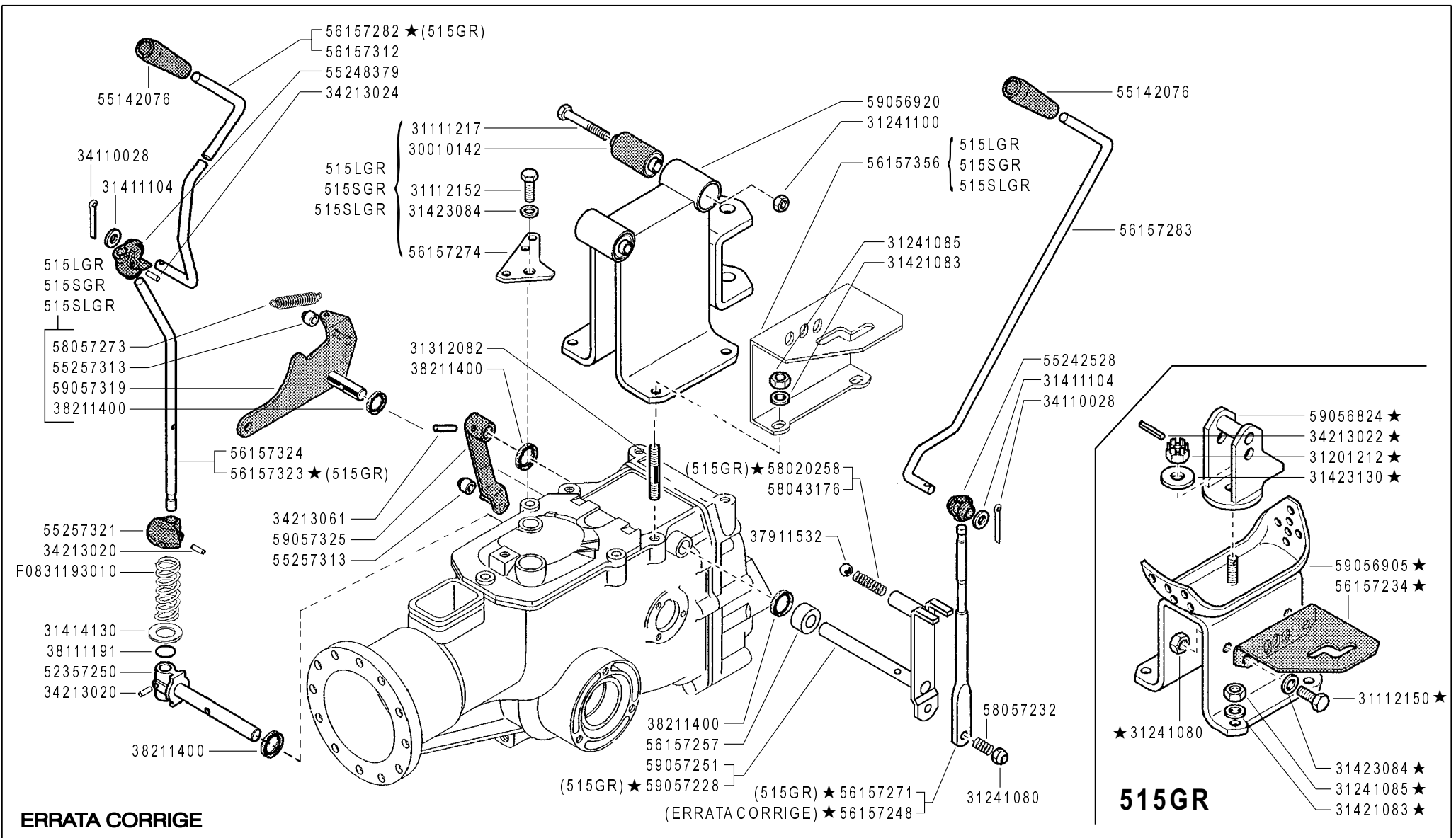

ERRATA CORRIGE

	500 serie GRIFON	COMANDI (515GR - 515L GR - 515S GR - 515SL GR ★)		DALLA MACCHINA DE LA MAQUINA DE LA MACHINE FROM THE MACHINE AB DER MASCHINE	Rev.
		CONTROLS MANDOS	COMMANDES ANTRIEBE		J01
				★N.	825532 (515GR)
				02/2009	

Pos.	Code	Q.ty	Description	Notes
56157282	56157282	1	ROD	
56157283	56157283	1	GEARSHIFT ROD	
56157312	56157312	1	ROD	
56157323	56157323	1	PTO LEVER	
56157324	56157324	1	PTO LEVER	
56157349	56157349	1	SELECTOR	
56157356	56157356	1	GEAR SELECTOR	
58020258	58020258	1	SPRING	
58043176	58043176	1	SPRING	
58057232	58057232	1	SPRING	
58057273	58057273	1	SPRING	
59056824	59056824	1	SUPPORT	
59056905	59056905	1	SUMP	
59056920	59056920	1	SUPPORT	
59057228	59057228	1	GEAR LEVER	
59057251	59057251	1	GEAR LEVER	
59057319	59057319	1	LEVER	
59057325	59057325	1	LEVER	
F0831193	F0831193010	1	SPRING DM.15X70	

SERIAL
START
825532

CONTROLS

Version: 515GR, 515L GR, 515S GR, 515SL GR

CODE REV

J01_1_67885

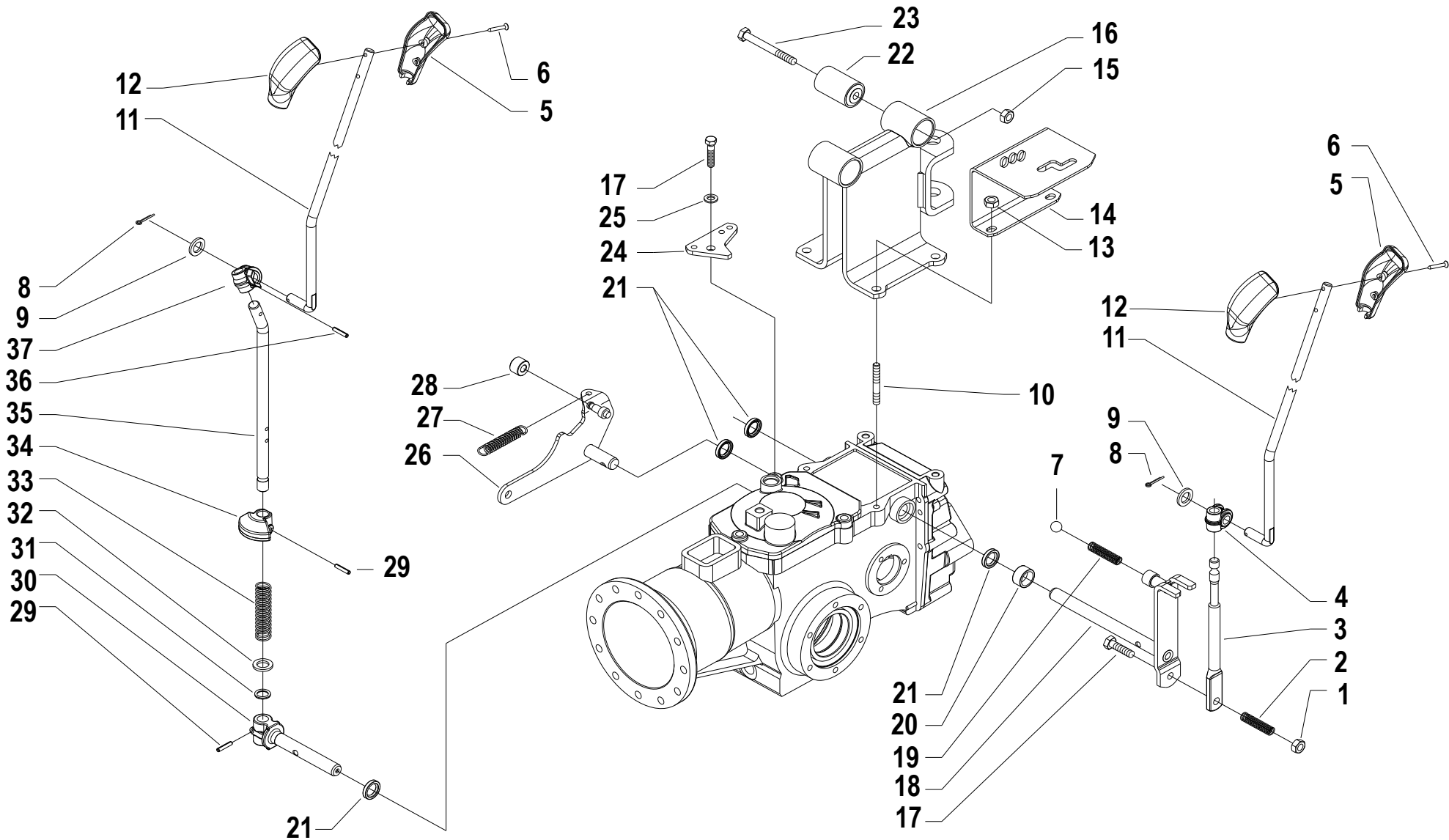

Pos.	Code	Q.ty	Description	Notes
1	31241080	1	HEXAGON SELFLOCK NUT M8	
2	58057232Z	1	SPRING	
3	56157271N	1	COMMAND LEVER	
4	55242528	1	JOINT	
5	55157213	1	GRIP	
6	31100451	1	SCREW 3,5X25	
7	37911532	1	BALL 15/32	
8	34110028	1	SPLIT PIN	
9	31411104	1	WASHER 10,5x18	
10	31312082	1	STUD BOLT M8X38X14X20	
11	56156792N	1	PULL ROD	
12	55157212	1	GRIP	
13	31241084	1	SELFLOCK NUT M8 6S	
14	56156195H	1	GEAR SELECTOR	
15	31241100	1	SELFLOCK HEXAGON NUT M10	
16	59056920	1	SUPPORT	
17	31112152	1	SCREW TE M8X30 UNI 5739 8G	
18	59057251N	1	GEAR LEVER	
19	58043176	1	SPRING	
20	56157257Z	1	SPACER	
21	38211400	1	OIL SEAL 14X22X4	
22	30010142	1	SILENT-BLOCK 10,2X30X45X49	
23	31111217	1	SCREW TE M10X75 UNI 5737 8G	
24	56157274	1	SQUARE	
25	31423084	1	SPRING WASHER 8,4	
26	59057319	1	LEVER	
27	58057273	1	SPRING	
28	55257313	1	ROLLER	
29	34213020	1	ROLL PIN	
30	52357250	1	PIN	
31	38111191	1	O-RING	
32	31414130	1	WASHER 13	
33	F0831193010	1	SPRING DM.15X70	
34	55257321	1	STOP	

SERIAL

CONTROLS

CODE REV

J.01.02.A0011_02

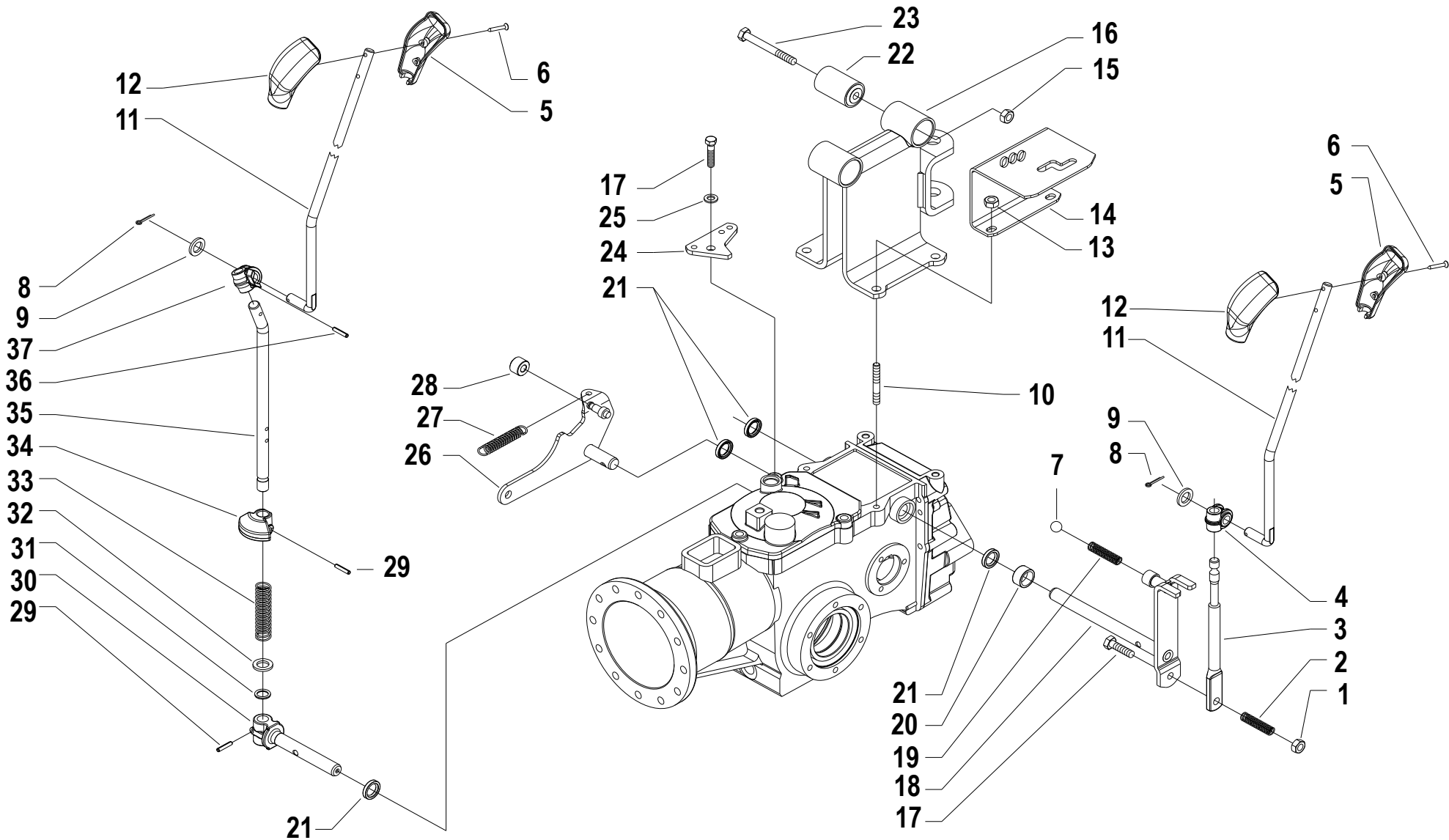

Pos.	Code	Q.ty	Description	Notes
35	56157324N	1	PTO LEVER	
36	34213024	1	ROLL PIN	
37	55248379	1	JOINT	

CONTROLS

SERIAL START 953111

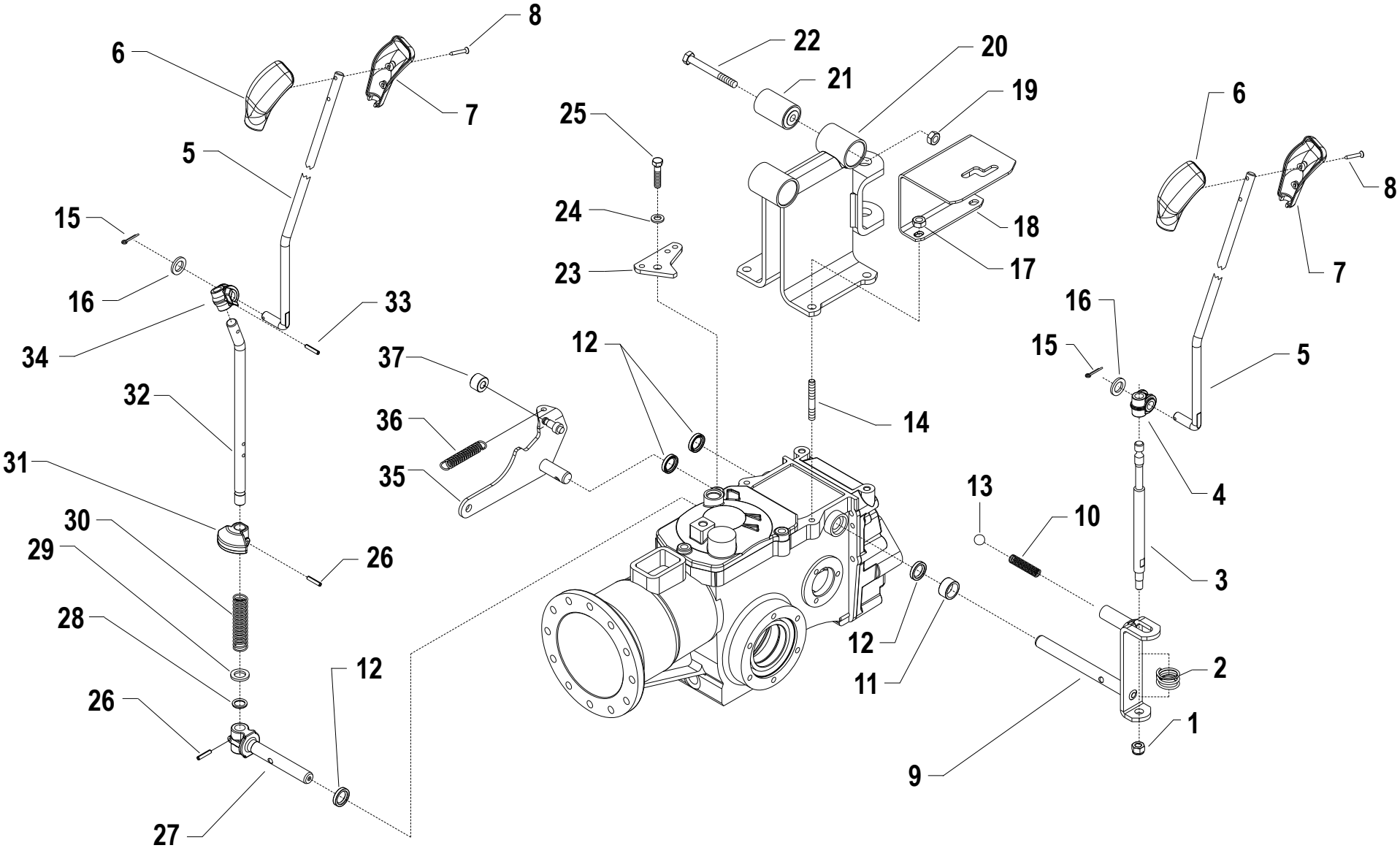

Pos.	Code	Q.ty	Description	Notes
1	31241080		HEXAGON SELFLOCK NUT M8	
2	58057232Z		SPRING	
3	563C1005Z		COMMAND LEVER	Replaces 56157271N + 59057251N
4	55242528		JOINT	
5	56156792Z		PULL ROD	
6	55157212		GRIP	
7	55157213		GRIP	
8	31100451		SCREW 3,5X25	
9	59056735N		GEAR LEVER	Replaces 56157271N + 59057251N
10	58043176		SPRING	
11	56157257Z		SPACER	
12	38211400		OIL SEAL 14X22X4	
13	37911532		BALL 15/32	
14	31312082		STUD BOLT M8X38X14X20	
15	34110028		SPLIT PIN	
16	31411104		WASHER 10,5x18	
17	31241084		SELFLOCK NUT M8 6S	
18	56156195H		GEAR SELECTOR	
19	31241100		SELFLOCK HEXAGON NUT M10	
20	59056920		SUPPORT	
21	30010142		SILENT-BLOCK 10,2X30X45X49	
22	31111217		SCREW TE M10X75 UNI 5737 8G	
23	56157274		SQUARE	
24	31423084		SPRING WASHER 8,4	
25	31112152		SCREW TE M8X30 UNI 5739 8G	
26	34213020		ROLL PIN	
27	52357250		PIN	
28	38111191		O-RING	
29	31414130		WASHER 13	
30	F0831193010		SPRING DM.15X70	
31	55257321		STOP	
32	56157324N		PTO LEVER	
33	34213024		ROLL PIN	
34	55248379		JOINT	

SERIAL
START
953111

CONTROLS

CODE REV

J.01.02.A0011_03

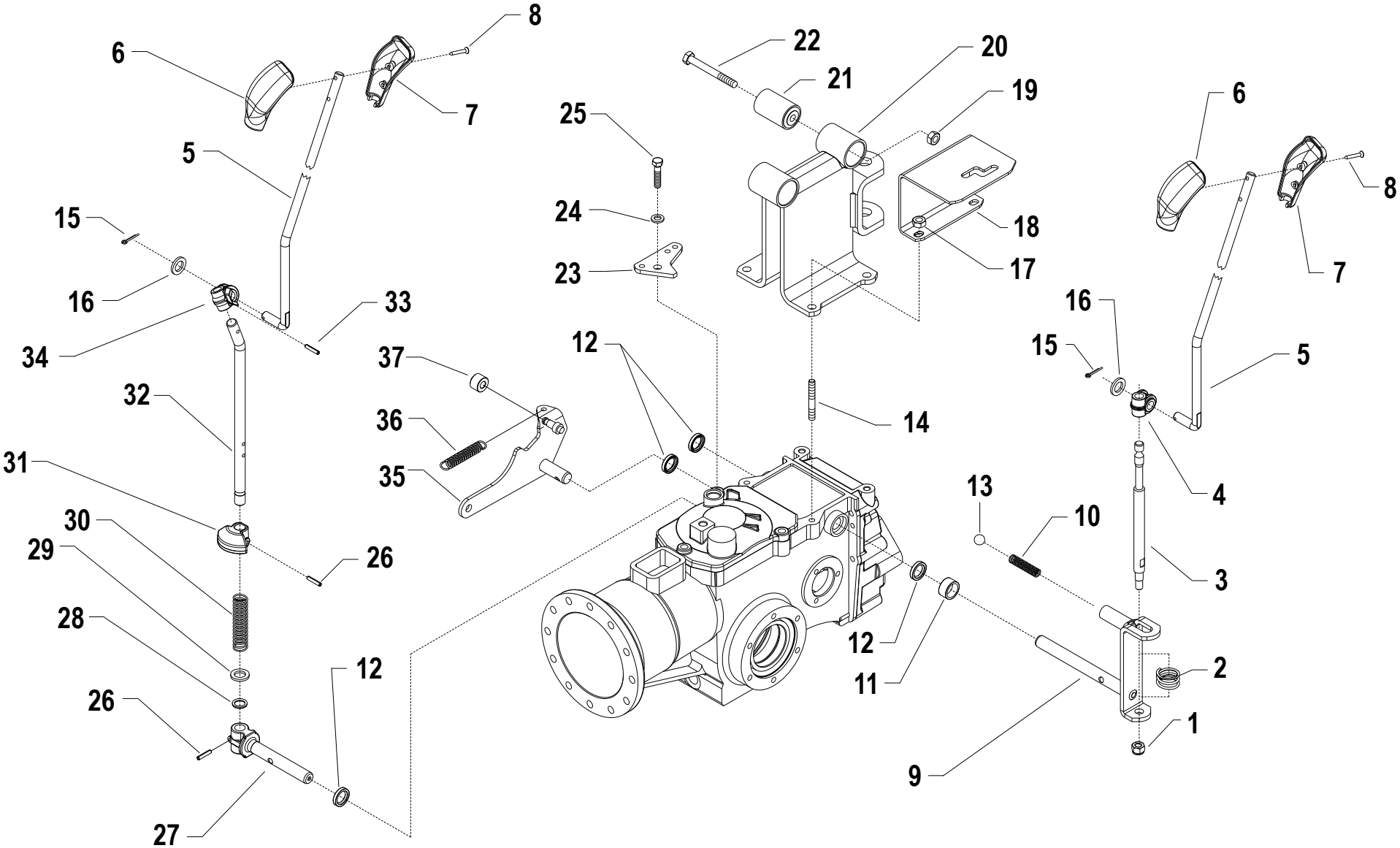

Pos.	Code	Q.ty	Description	Notes
35	59057319		LEVER	
36	58057273		SPRING	
37	55257313		ROLLER	

SERIAL
START
953111

CONTROLS

CODE REV
J.01.02.A0011_03

HANDLEBAR CONTROLS

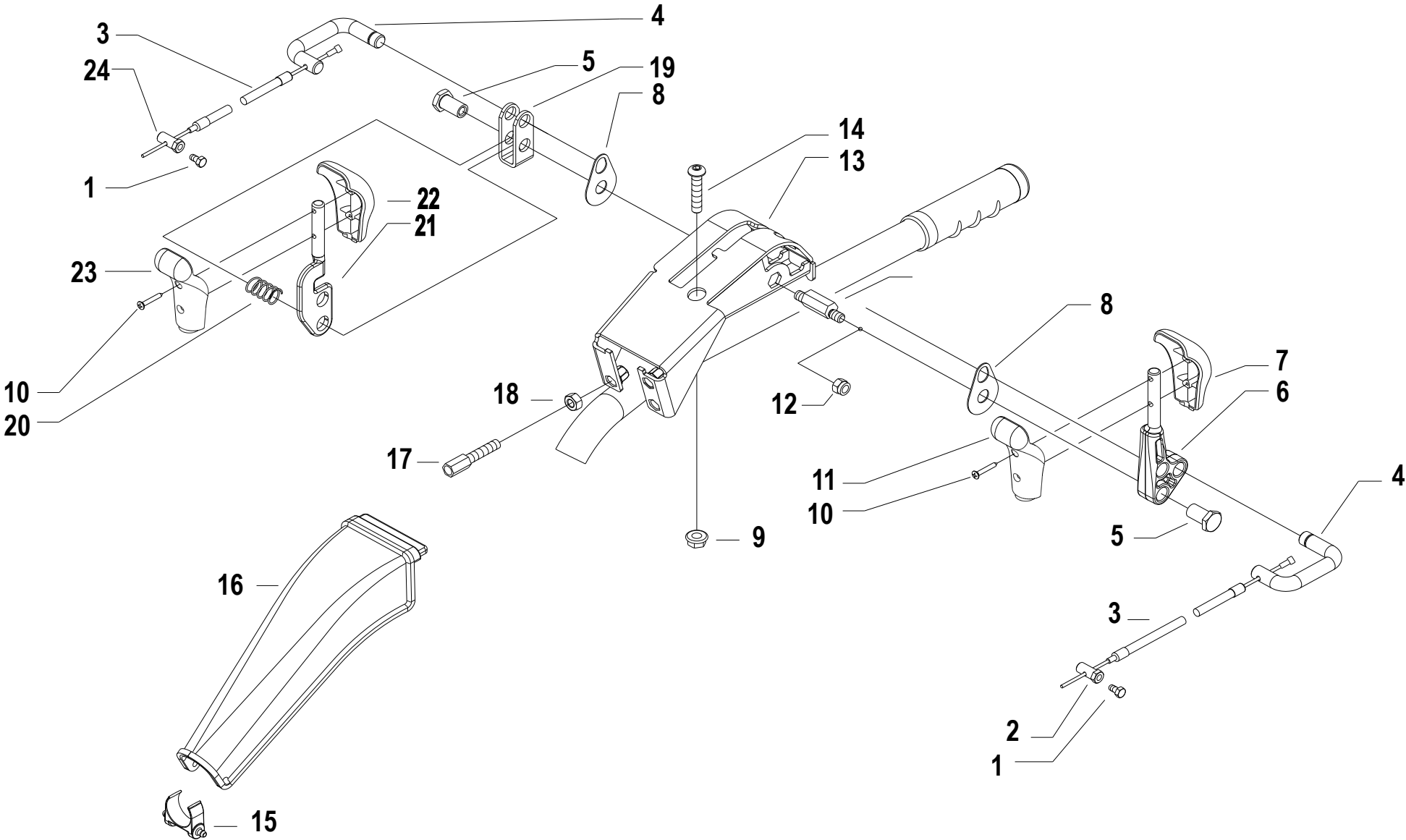

Pos.	Code	Q.ty	Description	Notes
1	31112090	1	SCREW TE M6X16 UNI 5739 8G	
2	56356840Z	1	CLAMPING SCREW	
3	58056848	1	LINE AND SHEATH	
4	56156832Z	1	U BOLT	
5	56148287	1	STUD BOLT	
6	53156860	1	COMMAND LEVER	
7	55157212	1	GRIP	
8	56356833Z	1	SMALL PLATE	
9	31241084	1	SELFLOCK NUT M8 6S	
10	31100451	1	SCREW 3,5X25	
11	55157213	1	GRIP	
12	31241084	1	SELFLOCK NUT M8 6S	
13	59256850	1	SUPPORT	
14	31121020	1	SCREW TBCEI M8X40 ISO7380 10K Z	
15	55256836	1	CROSS MEMBER	
16	55256835	1	PROTECTION COVER	
17	58056595	1	ADJUSTING SCREW	
18	31211080	1	NUT M8	
19	56156859Z	1	FORK	
20	58049830	1	SPRING	
21	52156810Z	1	COMMAND LEVER	
22	55157214	1	GRIP	
23	55157215	1	GRIP	
24	58042200	1	CLAMPING SCREW	

	A	B	C
3.50 - 8" (500)	39113502	39413502	58052325
3.50 - 8"	39113502	39413502	58052326
4.00 - 8"	39114008	39414008	58052326
4.0 - 10"	39114010	39414010	58052327
4.0 - 10"	39114010	39414010	58052289 (FIX) ★
5.0 - 10"	39115010	39415010	58052327
5.0 - 10"	39115010	39415010	58052289 (FIX) ★
6.5 / 8.0 - 12"	39116018	39416018	F0849044070
21 x 11.00 - 8"	39113501	TUBELESS	58052274
20 x 8.00 - 10"	39118021 (TR)	39416025	58052281
20 x 8.00 - 10"	39118020 (GA)	39415010	58052280 (S MUSTER)
16 x 6.50 - 8"	39111608	39411608	58052297 ★

92457794

KIT GEMELLAGGIO PER 4.0-10" / 5.0-10"
 TWINNING KIT FOR 4.0-10" / 5.0-10"
 JUMELAGE KIT POUR 4.0-10" / 5.0-10"
 KIT GEMELOS POR 4.0-10" / 5.0-10"
 ZWILLINGSKIT 4.0-10" / 5.0-10"

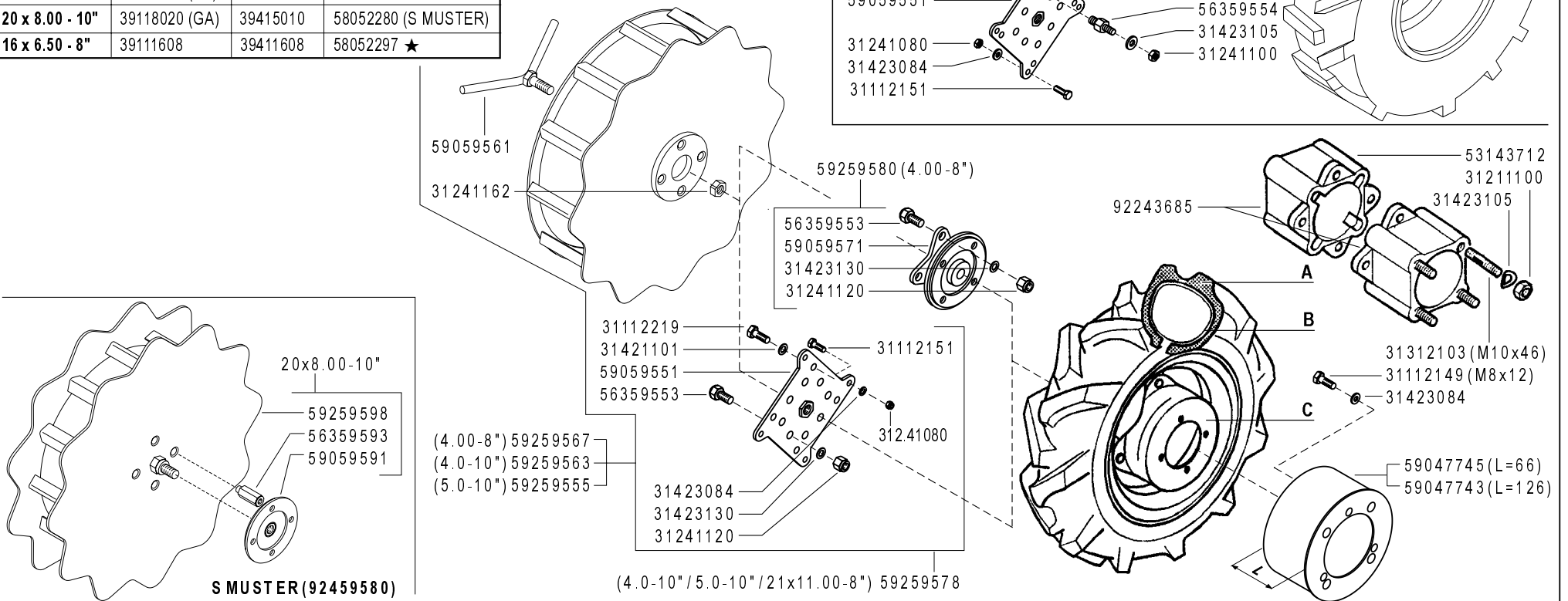

FERRARI

500 serie GRIFON

WHEELS
RUEDAS

RUOTE

ROUES
RÄDER

DALLA MACCHINA
DE LA MAQUINA
DE LA MACHINE
FROM THE MACHINE
AB DER MASCHINE

★ N.

AGGIORNAMENTO
REVISION
MISE A JOUR
APLAZAMIENTO
ANPASSUNG

L01

Rev.
2

01/2008

ZENNE

Pos.	Code	Q.ty	Description	Notes
31112149	31112149	1	SCREW TE M8X12 UNI 5739 8G	
31112151	31112151	1	SCREW TE M8X25 UNI 5739 8G	
31112219	31112219	1	SCREW TE M10X25 UNI 5739	
31211100	31211100	1	NUT M10	
31241080	31241080	1	HEXAGON SELFLOCK NUT M8	
31241100	31241100	1	SELFLOCK HEXAGON NUT M10	
31241120	31241120	1	SELFLOCK NUT M12	
31241162	31241162	1	SELFLOCK NUT	
31312103	31312103	1	STUD BOLT M10X46X24X16	
31421101	31421101	1	WASHER	
31423084	31423084	1	SPRING WASHER 8,4	
31423105	31423105	1	SPRING WASHER 10,5	
31423130	31423130	1	SPRING WASHER 13	
39111608	39111608	1	TYRE 16X6.50-8 4PR	
39113501	39113501	1	TYRE 21X11.00-8	
39113502	39113502	1	TYRE 3.50-8 2PR	
39114008	39114008	1	TYRE 4.00-8 2PR	
39114010	39114010	1	TYRE 4.0-10 2PR	
39115010	39115010	1	TYRE 5.00-10 2PR	
39116018	39116018	1	TYRE 6.5/80-12 2PR	
39118020	39118020	1	TYRE 20X8.00-10 4PR	
39118021	39118021	1	COVER	
39411608	39411608	1	INNER TUBE	
39413502	39413502	1	INNER TUBE	
39414008	39414008	1	INNER TUBE	
39414010	39414010	1	INNER TUBE	
39415010	39415010	1	INNER TUBE	
39416018	39416018	1	INNER TUBE	
39416025	39416025	1	INNER TUBE	
53143712	53143712	1	SPACER	
56359553	56359553	1	PIN	
56359554	56359554	1	PIN	
56359593	56359593	1	DRIVING PIN	
58052274	58052274	1	RIM	

SERIAL

L01_02 - WHEELS

CODE REV

L01_2_60486

	A	B	C
3.50 - 8" (500)	39113502	39413502	58052325
3.50 - 8"	39113502	39413502	58052326
4.00 - 8"	39114008	39414008	58052326
4.0 - 10"	39114010	39414010	58052327
4.0 - 10"	39114010	39414010	58052289 (FIX) ★
5.0 - 10"	39115010	39415010	58052327
5.0 - 10"	39115010	39415010	58052289 (FIX) ★
6.5 / 8.0 - 12"	39116018	39416018	F0849044070
21 x 11.00 - 8"	39113501	TUBELESS	58052274
20 x 8.00 - 10"	39118021 (TR)	39416025	58052281
20 x 8.00 - 10"	39118020 (GA)	39415010	58052280 (S MUSTER)
16 x 6.50 - 8"	39111608	39411608	58052297 ★

92457794

KIT GEMELLAGGIO PER 4.0-10" / 5.0-10"
 TWINNING KIT FOR 4.0-10" / 5.0-10"
 JUMELAGE KIT POUR 4.0-10" / 5.0-10"
 KIT GEMELOS POR 4.0-10" / 5.0-10"
 ZWILLINGSKIT 4.0-10" / 5.0-10"

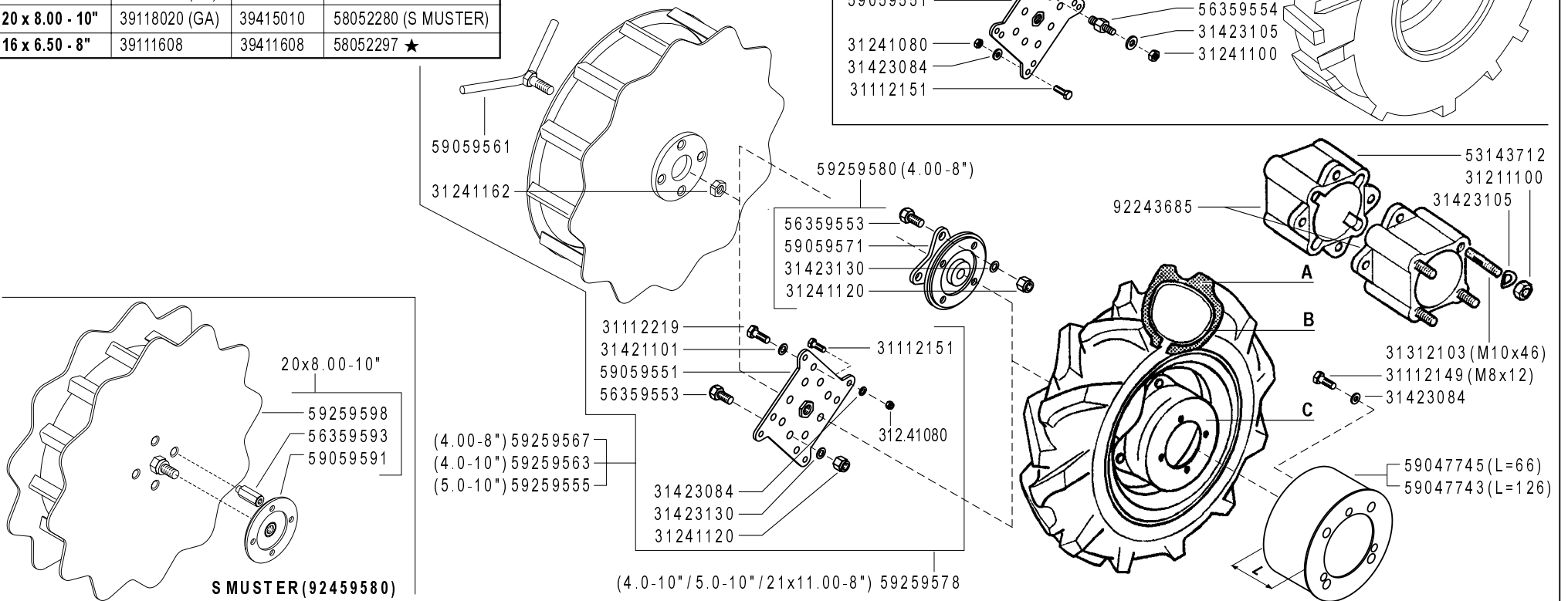

FERRARI

500 serie GRIFON

WHEELS
RUEDAS

RUOTE

ROUES
RÄDER

DALLA MACCHINA
DE LA MAQUINA
DE LA MACHINE
FROM THE MACHINE
AB DER MASCHINE

★ N.

AGGIORNAMENTO
REVISION
MISE A JOUR
APLAZAMIENTO
ANPASSUNG

L01

01/2008

Rev. 2

ZENNE

Pos.	Code	Q.ty	Description	Notes
58052280	58052280	1	RIM	
58052281	58052281	1	RIM	
58052289	58052289	1	RIM	
58052297	58052297	1	RIM	
58052325	58052325	1	RIM	
58052326	58052326	1	RIM	
58052327	58052327	1	RIM	
59047743	59047743	1	HUBCOVER	
59047745	59047745	1	HUBCOVER	
59059551	59059551	1	FLANGE	
59059561	59059561	1	SCREW	
59059571	59059571	1	FLANGE	
59059591	59059591	1	SPACER	
59259555	59259555	1	SUPER-BITE WHEEL X 5.00-10	
59259563	59259563	1	WHEEL	
59259567	59259567	1	WHEEL	
59259578	59259578	1	FLANGE KIT	
59259580	59259580	1	FLANGE KIT	
59259598	59259598	1	WHEEL	
92243685	92243685	1	PAIR WHEEL SPACERS 6 CM	
92457794	92457794	1	ADAPTOR PLATES 10 WHEELS (PAIR)	
92459580	92459580	1	COPPIA R.MARGHER.20X8.0-10 FER	
F0849044	F0849044070	1	WHEEL DISC	

	A	B	C
3.50 - 8" (500)	39113502	39413502	58043370 ★
3.50 - 8"	39113502	39413502	58043250 ★
4.00 - 8"	39114008	39414008	58043250 ★
4.0 - 10"	39114010	39415010 ★(1)	58048330 ★
5.0 - 10"	39115010	39415010	58048330 ★
6.5 / 80 - 12"	39116018	39416018	58044804 ★
21 x 11.00 - 8"	39113501	TUBELESS	58057795 ★
20 x 8.00 - 10"	39118021 (TR)	39416025	58057799 ★
20 x 8.00 - 10"	39118020 (GA)	39415010	58057797 ★ (S MUSTER)
16 x 6.50 - 8"	39111665 ★(2)	39411608	58057839 ★

(1) sostituisce 39414010
(2) ERRATA CORRIGE

92457794
KIT GEMELLAGGIO PER 4.0-10" / 5.0-10"
TWINNING KIT FOR 4.0-10" / 5.0-10"
JUMELAGE KIT POUR 4.0-10" / 5.0-10"
KIT GEMELOS POR 4.0-10" / 5.0-10"
ZWILLINGSKIT 4.0-10" / 5.0-10"

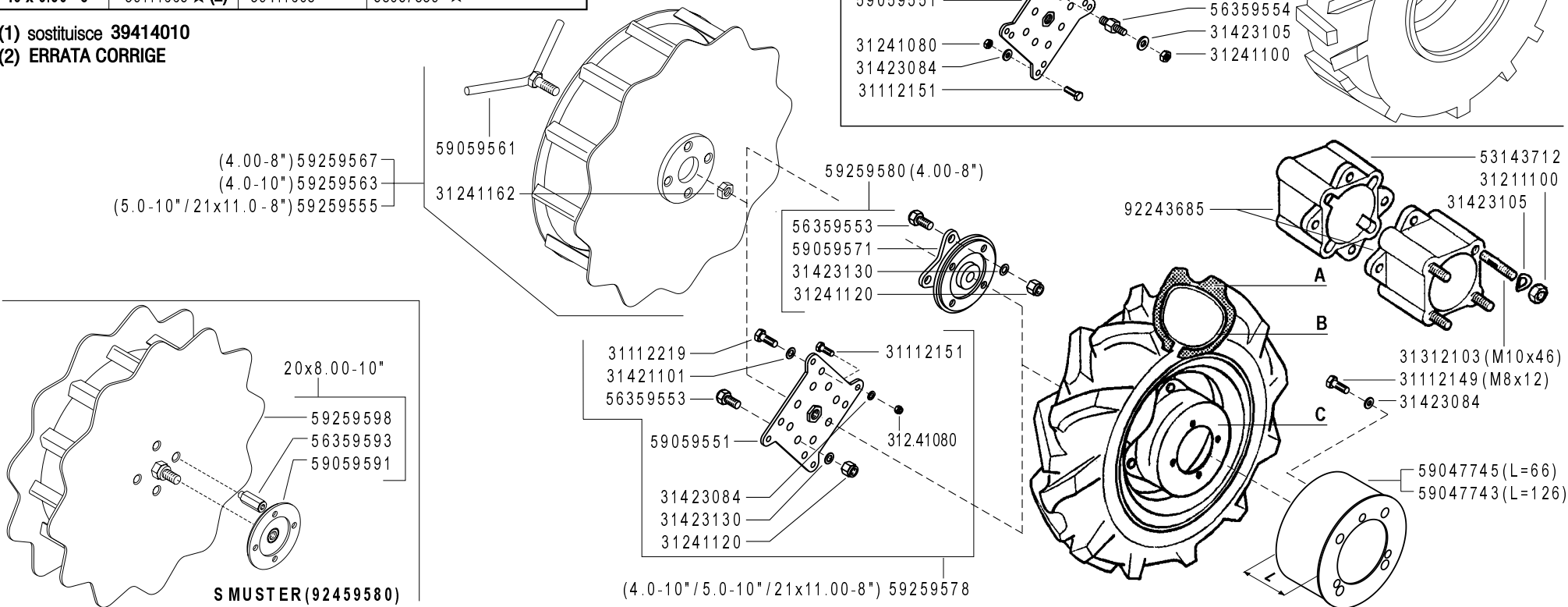

FERRARI

500 serie GRIFON

RUOTE

WHEELS
RUEDAS

ROUES
RÄDER

DALLA MACCHINA
DE LA MAQUINA
DE LA MACHINE
FROM THE MACHINE
AB DER MASCHINE

★ N.

AGGIORNAMENTO
REVISION
MISE A JOUR
APLAZAMIENTO
ANPASSUNG

L01

06/2010

Rev. 3

ZENNE

Pos.	Code	Q.ty	Description	Notes
31112151	31112151	1	SCREW TE M8X25 UNI 5739 8G	
31112219	31112219	1	SCREW TE M10X25 UNI 5739	
31211100	31211100	1	NUT M10	
31241080	31241080	1	HEXAGON SELFLOCK NUT M8	
31241100	31241100	1	SELFLOCK HEXAGON NUT M10	
31241120	31241120	1	SELFLOCK NUT M12	
31241162	31241162	1	SELFLOCK NUT	
31312103	31312103	1	STUD BOLT M10X46X24X16	
31421101	31421101	1	WASHER	
31423084	31423084	1	SPRING WASHER 8,4	
31423105	31423105	1	SPRING WASHER 10,5	
31423130	31423130	1	SPRING WASHER 13	
39111608	39111608	1	TYRE 16X6.50-8 4PR	
39111665	39111665	1	TYRE 16X6.50-8 4PR	
39113501	39113501	1	TYRE 21X11.00-8	
39113502	39113502	1	TYRE 3.50-8 2PR	
39114008	39114008	1	TYRE 4.00-8 2PR	
39114010	39114010	1	TYRE 4.0-10 2PR	
39115010	39115010	1	TYRE 5.00-10 2PR	
39116018	39116018	1	TYRE 6.5/80-12 2PR	
39118020	39118020	1	TYRE 20X8.00-10 4PR	
39118021	39118021	1	COVER	
39411608	39411608	1	INNER TUBE	
39413502	39413502	1	INNER TUBE	
39414008	39414008	1	INNER TUBE	
39415010	39415010	1	INNER TUBE	
39416018	39416018	1	INNER TUBE	
39416025	39416025	1	INNER TUBE	
53143712	53143712	1	SPACER	
56359553	56359553	1	PIN	
56359554	56359554	1	PIN	
56359593	56359593	1	DRIVING PIN	
58043250	58043250	1	RIM	
58043370	58043370	1	RIM	

SERIAL

L01_03 - WHEELS

CODE REV

L01_3_90714

	A	B	C
3.50 - 8" (500)	39113502	39413502	58043370 ★
3.50 - 8"	39113502	39413502	58043250 ★
4.00 - 8"	39114008	39414008	58043250 ★
4.0 - 10"	39114010	39415010 ★(1)	58048330 ★
5.0 - 10"	39115010	39415010	58048330 ★
6.5 / 80 - 12"	39116018	39416018	58044804 ★
21 x 11.00 - 8"	39113501	TUBELESS	58057795 ★
20 x 8.00 - 10"	39118021 (TR)	39416025	58057799 ★
20 x 8.00 - 10"	39118020 (GA)	39415010	58057797 ★ (S MUSTER)
16 x 6.50 - 8"	39111665 ★(2)	39411608	58057839 ★

(1) sostituisce 39414010
(2) ERRATA CORRIGE

92457794
KIT GEMELLAGGIO PER 4.0-10" / 5.0-10"
TWINNING KIT FOR 4.0-10" / 5.0-10"
JUMELAGE KIT POUR 4.0-10" / 5.0-10"
KIT GEMELOS POR 4.0-10" / 5.0-10"
ZWILLINGSKIT 4.0-10" / 5.0-10"

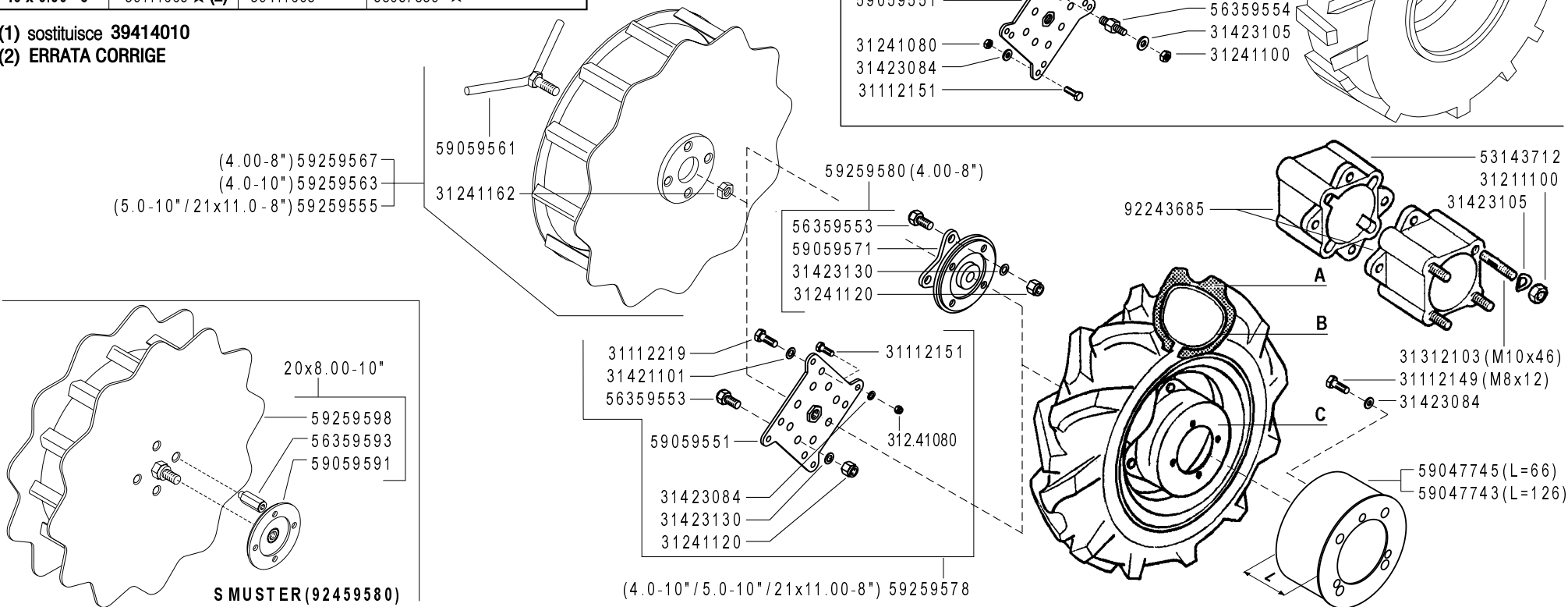

FERRARI

500 serie **GRIFON**

RUOTE

WHEELS
RUEDAS

ROUES
RÄDER

DALLA MACCHINA
DE LA MAQUINA
DE LA MACHINE
FROM THE MACHINE
AB DER MASCHINE

★ N.

AGGIORNAMENTO
REVISION
MISE A JOUR
APLAZAMIENTO
ANPASSUNG

L01

06/2010

Rev. **3**

ZENNE

Pos.	Code	Q.ty	Description	Notes
58044804	58044804	1	RIM	
58048330	58048330	1	RIM	
58057795	58057795	1	RIM	
58057797	58057797	1	RIM	
58057799	58057799	1	RIM	
58057839	58057839	1	RIM	
59047743	59047743	1	HUBCOVER	
59047745	59047745	1	HUBCOVER	
59059551	59059551	1	FLANGE	
59059561	59059561	1	SCREW	
59059571	59059571	1	FLANGE	
59059591	59059591	1	SPACER	
59259555	59259555	1	SUPER-BITE WHEEL X 5.00-10	
59259563	59259563	1	WHEEL	
59259567	59259567	1	WHEEL	
59259578	59259578	1	FLANGE KIT	
59259580	59259580	1	FLANGE KIT	
59259598	59259598	1	WHEEL	
92243685	92243685	1	PAIR WHEEL SPACERS 6 CM	
92457794	92457794	1	ADAPTOR PLATES 10 WHEELS (PAIR)	
92459580	92459580	1	COPPIA R.MARGHER.20X8.0-10 FER	

500 GRIFON

58052165

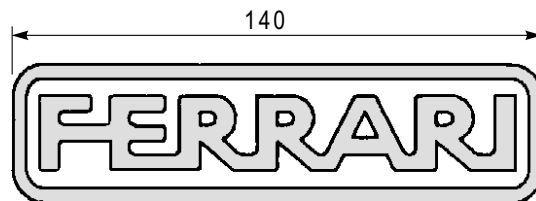

58052029



58052160

515 GRIFON

58052157

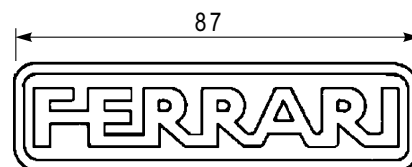

58052019 ★

515L GRIFON

58052158

520 GRIFON

58052162

515S GRIFON

58052159

530 GRIFON

58052163

515SL GRIFON

58052167 ★

530S GRIFON

58052164

FERRARI

500 serie GRIFON

ADESIVI

STICKERS
ADHESIVOS

AUTOCOLLANTS
AUFKLEBES

DALLA MACCHINA
DE LA MAQUINA
DE LA MACHINE
FROM THE MACHINE
AB DER MASCHINE

★N.

AGGIORNAMENTO
REVISION
MISE A JOUR
APLAZAMIENTO
ANPASSUNG

M01

Rev.
2

02/2009

ZENNE

Pos.	Code	Q.ty	Description	Notes
58052019	58052019	1	DECAL	
58052029	58052029	1	DECAL	
58052157	58052157	1	DECAL	
58052158	58052158	1	DECAL	
58052159	58052159	1	DECAL	
58052160	58052160	1	DECAL	
58052162	58052162	1	DECAL	
58052163	58052163	1	DECAL	
58052164	58052164	1	DECAL	
58052165	58052165	1	DECAL	
58052167	58052167	1	DECAL	

500 GRIFON 58052165

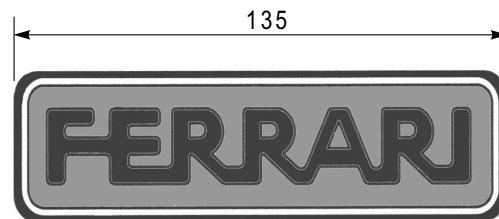

53052176 ★

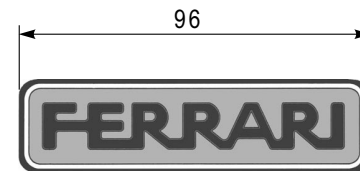

53052175 ★

515 GRIFON 58052183 ★

530 S

58052190 ★

515L GRIFON 58052184 ★

520 GRIFON 58052187 ★

515S GRIFON 58052185 ★

530 GRIFON 58052188 ★

515SL GRIFON 58052186 ★

530S GRIFON 58052189 ★

FERRARI

500 serie **GRIFON**

ADESIVI

STICKERS
ADHESIVOS

AUTOCOLLANTS
AUFKLEBES

DALLA MACCHINA
DE LA MAQUINA
DE LA MACHINE
FROM THE MACHINE
AB DER MASCHINE

AGGIORNAMENTO

REVISION

MISE A JOUR

APLAZAMIENTO

ANPASSUNG

★N.

M01

Rev.
3

11/2010

ZENNE

Pos.	Code	Q.ty	Description	Notes
53052175	53052175	1	MEDIUM FERRARI BRAND	
53052176	53052176	1	BIG FERRARI BRAND	
58052165	58052165	1	DECAL	
58052183	58052183	1	DECAL	
58052184	58052184	1	DECAL	
58052185	58052185	1	DECAL	
58052186	58052186	1	DECAL	
58052187	58052187	1	DECAL	
58052188	58052188	1	DECAL	
58052189	58052189	1	DECAL	
58052190	58052190	1	DECAL	



580.57698

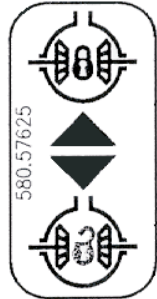

580.57625

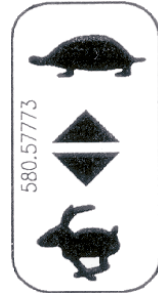

580.57773

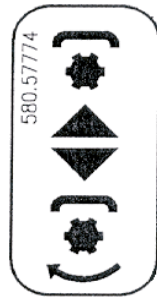

580.57774

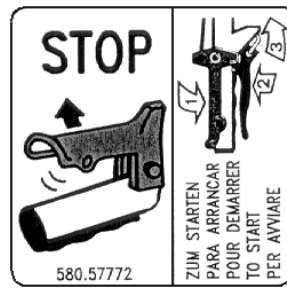

580.57772

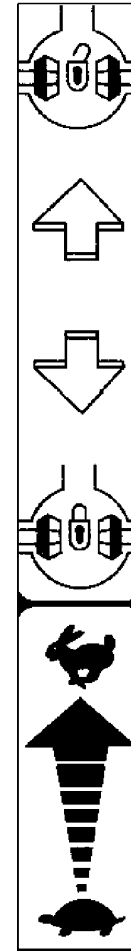

580.57688★



580.57706



580.57767



580.57768

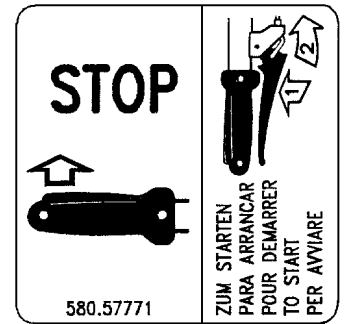

580.57771

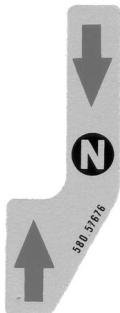

580.57676



580.57712



580.57678



580.57722

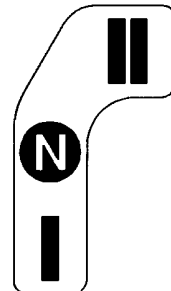

580.57732



580.93089



580.57724



580.57770

FERRARI

500 serie GRIFON

ADESIVI

STICKERS
ADHESIVOS

AUTOCOLLANTS
AUFKLEBES

DALLA MACCHINA
DE LA MAQUINA
DE LA MACHINE
FROM THE MACHINE
AB DER MASCHINE

AGGIORNAMENTO

REVISION

MISE A JOUR

APLAZAMIENTO

ANPASSUNG

★ N.

Rev. **M02** 2

02/2009

ZENNE

Pos.	Code	Q.ty	Description	Notes
58046912	58046912	1	DECAL	
58057625	58057625	1	DECAL	
58057676	58057676	1	DECAL	
58057678	58057678	1	DECAL	
58057688	58057688	1	DECAL	
58057698	58057698	1	DECAL	
58057706	58057706	1	DECAL	
58057712	58057712	1	DECAL	
58057722	58057722	1	DECAL	
58057724	58057724	1	DECAL	
58057732	58057732	1	DECAL	
58057746	58057746	1	DECAL	
58057747	58057747	1	DECAL	
58057748	58057748	1	DECAL	
58057767	58057767	1	DECAL	
58057768	58057768	1	DECAL	
58057770	58057770	1	DECAL	
58057771	58057771	1	DECAL	
58057772	58057772	1	DECAL	
58057773	58057773	1	DECAL	
58057774	58057774	1	DECAL	
58093089	58093089	1	DECAL	



580.57458



58056864

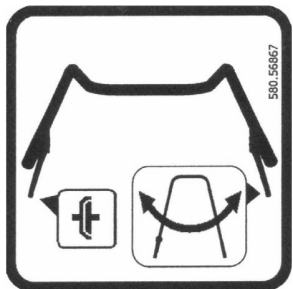

58056867

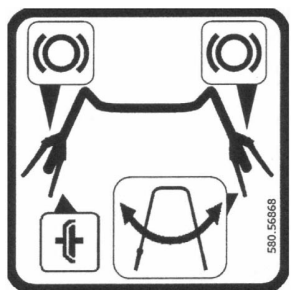

58056868

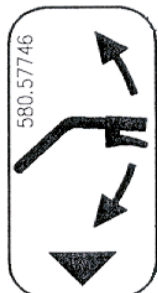

58057746

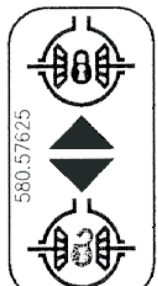

58057625



58093089



580.57747

58057747

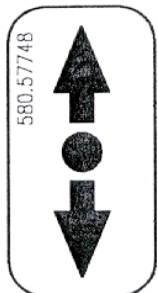

58057748

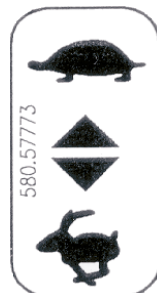

58057773



58057774



58057767



58057768

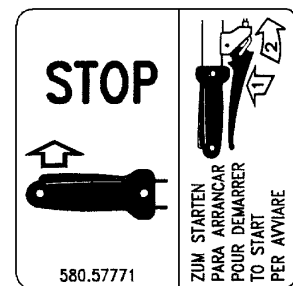

580.57771

58057771



580.57772

58057772



58057678



KUPPLUNG
EMBRAYAGE
CLUTCH
FRIZIONE

58057770



58057722



58057724

ZUM STARTEN

- KUPPLUNGHEBEL ANHAKEN, (SIEHE) AUFKLEBER AUF DEM LENKHOLM).
 - GASHEBEL ZUR MITTE EINSTELLEN.
 - BENZINHAHN OFFNEN (WENN VORHANDEN).
 - CHOKE SCHLIESSEN (BEI KALTEM MOTOR).
- DEN FUSS IN DIE RICHTIGE STELLUNG SETZEN.**



ZUM STARTEN

- DEN SEIL AUF DIE STARTSCHEIBE AUFWICKELN (WENN KEIN REVERSIERSTARTER VORHANDEN IST).
- DER STARTERGRIFF IN ENTSCHLOSSENER WEISE ZIEHEN, BEI DEM ELEKTROSTARTER SCHLUSSEL DREHEN.
- CHOKE DEFNEN.

ADESIVI

STICKERS
ADHESIVOS

AUTOCOLLANTS
AUFKLEBES

DALLA MACCHINA
DE LA MAQUINA
DE LA MACHINE
FROM THE MACHINE
AB DER MASCHINE

★ N.

867450 (520-530-S)
863996 (515L-S-SL)
864056 (515)

M02

11/2010

Rev. 3

ZENNE

FERRARI

500 serie GRIFON

Pos.	Code	Q.ty	Description	Notes
58046932	58046932	1	DECAL	
58056864	58056864	1	DECAL	
58056867	58056867	1	DECAL	
58056868	58056868	1	DECAL	
58057458	58057458	1	DECAL	
58057625	58057625	1	DECAL	
58057676	58057676	1	DECAL	
58057678	58057678	1	DECAL	
58057722	58057722	1	DECAL	
58057724	58057724	1	DECAL	
58057732	58057732	1	DECAL	
58057746	58057746	1	DECAL	
58057747	58057747	1	DECAL	
58057748	58057748	1	DECAL	
58057767	58057767	1	DECAL	
58057768	58057768	1	DECAL	
58057770	58057770	1	DECAL	
58057771	58057771	1	DECAL	
58057772	58057772	1	DECAL	
58057773	58057773	1	DECAL	
58057774	58057774	1	DECAL	
58093089	58093089	1	DECAL	

SPARE PARTS INSTANCE INDEX





SPARE PARTS INSTANCE INDEX

Code	Parts Table	Pos.	Q.ty	Code	Parts Table	Pos.	Q.ty	Code	Parts Table	Pos.	Q.ty
0	C01_2_67668	0	1	31111229	H01_2_67804	31111229	1	31112213	C.01.02.A0011_04	6	
30010103	I01_2_67839	30010103	1	31112081	C.01.02.A0011_04	10			C01_2_67668	31112213	1
30010142	J.01.02.A0011_02	22	1	31112083	E.01.02.A0011_03	3	1	31112217	H.01.02.A0011_03	42	1
	J.01.02.A0011_03	21			E.01.02.A0011_04	3			H01_2_67804	31112217	1
	J01_1_67885	30010142	1	31112085	C.01.02.A0011_03	4	1		I01_2_67839	31112217	1
30040001	E.01.02.A0011_03	16	1	31112089	I.01.02.A0011_03	1	1	31112219	L01_2_60486	31112219	1
	E.01.02.A0011_04	11			I.01.02.A0011_04	1	1		L01_3_90714	31112219	1
	E01_2_67697	30040001	1		I01_2_67839	31112089	1	31112293	H.01.02.A0011_03	22	1
30040133Z	E.01.02.A0011_03	19	1	31112090	J.03.02.A0011_00	1	1		H01_2_67804	31112293	1
	E.01.02.A0011_04	18		31112092	I.01.02.A0011_03	11	1	31112294	H.01.02.A0011_03	41	1
	E01_2_67697	30040133	1		I.01.02.A0011_04	11	1		H01_2_67804	31112294	1
31100003	D.01.02.A0019_05	12	1		I01_2_67839	31112092	1	31121007	C.01.02.A0011_03	15	1
	D.01.02.A0019_06	11		31112093	C01_2_67668	31112093	1		C01_2_67668	31121007	1
	D01_3_59819	31100003	1	31112149	L01_2_60486	31112149	1	31121020	I.01.02.A0011_03	24	1
	D01_4_72864	31100003	1	31112150	J01_1_67885	31112150	1		I.01.02.A0011_04	24	1
31100015	D.01.02.A0019_05	12	1	31112151	L01_2_60486	31112151	1		J.03.02.A0011_00	14	1
	D.01.02.A0019_06	11			L01_3_90714	31112151	1	31121024	H.01.02.A0011_03	24	1
	D01_3_59819	31100015	1	31112152	G05_0_67776	31112152	1	31132562	E.01.02.A0011_03	2	1
	D01_4_72864	31100015	1		J.01.02.A0011_02	17	1		E.01.02.A0011_04	2	
31100451	H.01.02.A0011_03	4	1		J.01.02.A0011_03	25			E01_2_67697	31132562	1
	J.01.02.A0011_02	6	1		J01_1_67885	31112152	1	31152084	I01_2_67839	31152084	1
	J.01.02.A0011_03	8		31112153	H01_2_67804	31112153	1	31152103	E.01.02.A0011_03	25	1
	J.03.02.A0011_00	10	1		I01_2_67839	31112153	1		E.01.02.A0011_04	21	
31111086	H01_2_67804	31111086	1	31112154	C.01.02.A0011_03	5	1		E01_2_67697	31152103	1
	I01_2_67839	31111086	1		C.01.02.A0011_04	6		31201212	J01_1_67885	31201212	1
31111090	E01_2_67697	31111090	1		C01_2_67668	31112154	1	31211040	I01_2_67839	31211040	1
31111091	I01_2_67839	31111091	1	31112165	H.01.02.A0011_03	7	1	31211080	D.01.02.A0019_05	11	1
31111097	I.01.02.A0011_03	5	1	31112166	G.05.02.A0011_01	22	1		D01_3_59819	31211080	1
	I.01.02.A0011_04	5	1	31112167	G.05.02.A0011_01	18	1		D01_4_72864	31211080	1
	I01_2_67839	31111097	1	31112170	H.01.02.A0011_03	31	1		H.01.02.A0011_03	29	1
31111217	J.01.02.A0011_02	23	1		H01_2_67804	31112170	1		H01_2_67804	31211080	1
	J.01.02.A0011_03	22		31112211	F.02.02.A0011_03	24			I.01.02.A0011_03	16	1
	J01_1_67885	31111217	1		F02_2_67738	31112211	1		I.01.02.A0011_04	16	1
31111229	H.01.02.A0011_03	6	1	31112213	C.01.02.A0011_03	5	1		I01_2_67839	31211080	1



SPARE PARTS INSTANCE INDEX

Code	Parts Table	Pos.	Q.ty	Code	Parts Table	Pos.	Q.ty	Code	Parts Table	Pos.	Q.ty
31211080	J.03.02.A0011_00	18	1	31241084	E.01.02.A0011_04	7		31312082	J01_1_67885	31312082	1
31211100	G.05.02.A0011_01	1	1		G.05.02.A0011_01	27	1	31312083	D.01.02.A0019_05	9	1
	G05_0_67776	31211100	1		J.01.02.A0011_02	13	1		D.01.02.A0019_06	9	
	L01_2_60486	31211100	1		J.01.02.A0011_03	17			D01_3_59819	31312083	1
	L01_3_90714	31211100	1		J.03.02.A0011_00	9	1		D01_4_72864	31312083	1
31221121	E.01.02.A0011_03	10	1		J.03.02.A0011_00	12	1	31312086	E.01.02.A0011_03	15	1
	E.01.02.A0011_04	10		31241085	E01_2_67697	31241085	1		E.01.02.A0011_04	12	
	E01_2_67697	31221121	1		J01_1_67885	31241085	1		E01_2_67697	31312086	1
31241060	C01_2_67668	31241060	1	31241100	C.01.02.A0011_03	7	1	31312088	D.01.02.A0019_05	9	1
	I.01.02.A0011_03	14	1		C.01.02.A0011_04	8			D01_3_59819	31312088	1
	I.01.02.A0011_04	14	1		C01_2_67668	31241100	1		D01_4_72864	31312088	1
	I01_2_67839	31241060	1		H.01.02.A0011_03	14	1	31312094	E.01.02.A0011_03	5	1
31241065	C.01.02.A0011_03	3	1		H01_2_67804	31241100	1		E.01.02.A0011_04	5	
31241066	C.01.02.A0011_04	9			I01_2_67839	31241100	1		E01_2_67697	31312094	1
31241080	C.01.02.A0011_03	7	1		J.01.02.A0011_02	15	1	31312102	G.05.02.A0011_01	3	1
	C.01.02.A0011_04	8			J.01.02.A0011_03	19			G05_0_67776	31312102	1
	C01_2_67668	31241080	1		J01_1_67885	31241100	1	31312103	L01_2_60486	31312103	1
	D.01.02.A0019_05	11	1		L01_2_60486	31241100	1		L01_3_90714	31312103	1
	D01_3_59819	31241080	1		L01_3_90714	31241100	1	31312124	E.01.02.A0011_03	8	1
	D01_4_72864	31241080	1	31241120	H.01.02.A0011_03	45	1		E.01.02.A0011_04	8	
	E.01.02.A0011_03	23	1		H01_2_67804	31241120	1		E01_2_67697	31312124	1
	E01_2_67697	31241080	1		L01_2_60486	31241120	1	31312125	E.01.02.A0011_03	8	1
	G.05.02.A0011_01	12	1		L01_3_90714	31241120	1		E.01.02.A0011_04	8	
	G05_0_67776	31241080	1	31241126	H.01.02.A0011_03	15	1		E01_2_67697	31312125	1
	H.01.02.A0011_03	11	1		H01_2_67804	31241126	1	31411043	H01_2_67804	31411043	1
	H01_2_67804	31241080	1	31241162	L01_2_60486	31241162	1		I01_2_67839	31411043	1
	I01_2_67839	31241080	1		L01_3_90714	31241162	1	31411064	C01_2_67668	31411064	1
	J.01.02.A0011_02	1	1	31312080	G.05.02.A0011_01	14	1		I01_2_67839	31411064	1
	J.01.02.A0011_03	1			G05_0_67776	31312080	1	31411084	C.01.02.A0011_03	6	1
	J01_1_67885	31241080	1	31312082	E.01.02.A0011_03	13	1		C.01.02.A0011_04	7	
	L01_2_60486	31241080	1		E.01.02.A0011_04	22			C01_2_67668	31411084	1
	L01_3_90714	31241080	1		E01_2_67697	31312082	1		G05_0_67776	31411084	1
31241083	D.01.02.A0019_06	10			J.01.02.A0011_02	10	1		I01_2_67839	31411084	1
31241084	E.01.02.A0011_03	7	1		J.01.02.A0011_03	14		31411104	C.01.02.A0011_03	6	1



SPARE PARTS INSTANCE INDEX

Code	Parts Table	Pos.	Q.ty
31411104	C.01.02.A0011_04	7	
	C01_2_67668	31411104	1
	J.01.02.A0011_02	9	1
	J.01.02.A0011_03	16	
	J01_1_67885	31411104	1
31414130	J.01.02.A0011_02	32	1
	J.01.02.A0011_03	29	
	J01_1_67885	31414130	1
31421083	C.01.02.A0011_03	14	1
	C01_2_67668	31421083	1
	E.01.02.A0011_03	22	1
	E01_2_67697	31421083	1
	J01_1_67885	31421083	1
31421100Z	H.01.02.A0011_03	16	1
	H01_2_67804	31421100	1
31421101	F.02.02.A0011_03	25	
	F02_2_67738	31421101	1
	L01_2_60486	31421101	1
	L01_3_90714	31421101	1
31421130	E.01.02.A0011_03	9	1
	E.01.02.A0011_04	9	
	H.01.02.A0011_03	44	1
	H01_2_67804	31421130	1
31422064	E01_2_67697	31422064	1
31423043	I01_2_67839	31423043	1
31423084	D.01.02.A0019_05	10	1
	D.01.02.A0019_06	13	
	D01_3_59819	31423084	1
	D01_4_72864	31423084	1
	E01_2_67697	31423084	1
	G.05.02.A0011_01	13	1
	G05_0_67776	31423084	1
	H01_2_67804	31423084	1
	I01_2_67839	31423084	1

Code	Parts Table	Pos.	Q.ty
31423084	J.01.02.A0011_02	25	1
	J.01.02.A0011_03	24	
	J01_1_67885	31423084	1
	L01_2_60486	31423084	1
	L01_3_90714	31423084	1
31423105	D.01.02.A0019_05	13	1
	D.01.02.A0019_06	13	
	D01_3_59819	31423105	1
	D01_4_72864	31423105	1
	G.05.02.A0011_01	2	1
	G05_0_67776	31423105	1
	H.01.02.A0011_03	43	1
	H01_2_67804	31423105	1
	I01_2_67839	31423105	1
	L01_2_60486	31423105	1
	L01_3_90714	31423105	1
31423130	E01_2_67697	31423130	1
	J01_1_67885	31423130	1
	L01_2_60486	31423130	1
	L01_3_90714	31423130	1
34110028	J.01.02.A0011_02	8	1
	J.01.02.A0011_03	15	
	J01_1_67885	34110028	1
34211028	H.01.02.A0011_03	33	1
	H01_2_67804	34211028	1
34211041	H.01.02.A0011_03	38	1
	H01_2_67804	34211041	1
34211042	F.02.02.A0011_03	17	
	F02_2_67738	34211042	1
34213020	I01_2_67839	34213020	1
	J.01.02.A0011_02	29	1
	J.01.02.A0011_03	26	
	J01_1_67885	34213020	1
34213022	J01_1_67885	34213022	1

Code	Parts Table	Pos.	Q.ty
34213024	J.01.02.A0011_02	36	1
	J.01.02.A0011_03	33	
	J01_1_67885	34213024	1
34213060	F.02.02.A0011_03	19	
	F02_2_67738	34213060	1
34213061	F.02.02.A0011_03	21	
	F02_2_67738	34213061	1
	J01_1_67885	34213061	1
34221070	H.01.02.A0011_03	39	1
	H01_2_67804	34221070	1
35111047	G.05.02.A0011_01	9	1
	G05_0_67776	35111047	1
35111052	F.02.02.A0011_03	30	
	F02_2_67738	35111052	1
35111055	F.02.02.A0011_03	8	
	F02_2_67738	35111055	1
35121014	E.01.02.A0011_03	29	1
	E01_2_67697	35121014	1
35121031	F.02.02.A0011_03	6	
	F02_2_67738	35121031	1
35211120	F.02.02.A0011_03	31	
	F02_2_67738	35211120	1
37111150	F.02.02.A0011_03	1	
	F02_2_67738	37111150	1
37111152	F.02.02.A0011_03	34	
	F02_2_67738	37111152	1
37111202	G05_0_67776	37111202	1
37111250	F02_2_67738	37111250	1
	G.05.02.A0011_01	11	1
37111253	G.05.02.A0011_01	8	1
	G05_0_67776	37111253	1
37111255	F.02.02.A0011_03	28	
37112173	D.01.02.A0019_05	7	1
	D.01.02.A0019_06	7	



SPARE PARTS INSTANCE INDEX

Code	Parts Table	Pos.	Q.ty	Code	Parts Table	Pos.	Q.ty	Code	Parts Table	Pos.	Q.ty
37112173	D01_3_59819	37112173	1	39114008	L01_3_90714	39114008	1	52443852N	G05_0_67776	52443852	1
	D01_4_72864	37112173	1	39114010	L01_2_60486	39114010	1	52443853N	G05_0_67776	52443853	1
37112229	F.02.02.A0011_03	7			L01_3_90714	39114010	1	52447896	D.01.02.A0019_05	8	1
	F02_2_67738	37112229	1	39115010	L01_2_60486	39115010	1		D.01.02.A0019_06	8	
37320120	F.02.02.A0011_03	14			L01_3_90714	39115010	1		D01_3_59819	52447896	1
	F02_2_67738	37320120	1	39116018	L01_2_60486	39116018	1		D01_4_72864	52447896	1
37910832	F.02.02.A0011_03	12			L01_3_90714	39116018	1	52448182	G05_0_67776	52448182	1
	F02_2_67738	37910832	1	39118020	L01_2_60486	39118020	1	52448187	G.05.02.A0011_01	6	1
37911532	J.01.02.A0011_02	7	1		L01_3_90714	39118020	1	52448188N	G.05.02.A0011_01	28	1
	J.01.02.A0011_03	13		39118021	L01_2_60486	39118021	1	52456335	F.02.02.A0011_03	10	
	J01_1_67885	37911532	1		L01_3_90714	39118021	1		F02_2_67738	52456335	1
38111191	J.01.02.A0011_02	31	1	39411608	L01_2_60486	39411608	1	52456339	F.02.02.A0011_03	33	
	J.01.02.A0011_03	28			L01_3_90714	39411608	1		F02_2_67738	52456339	1
	J01_1_67885	38111191	1	39413502	L01_2_60486	39413502	1	52456349	F.02.02.A0011_03	26	
38111400	G.05.02.A0011_01	23	1		L01_3_90714	39413502	1		F02_2_67738	52456349	1
	G05_0_67776	38111400	1	39414008	L01_2_60486	39414008	1	52456362	F02_2_67738	52456362	1
	J01_1_67885	38111400	1		L01_3_90714	39414008	1	52456370	F.02.02.A0011_03	3	
38211400	J.01.02.A0011_02	21	1	39414010	L01_2_60486	39414010	1		F02_2_67738	52456370	1
	J.01.02.A0011_03	12		39415010	L01_2_60486	39415010	1	52456389	F.02.02.A0011_03	20	
	J01_1_67885	38211400	1		L01_3_90714	39415010	1		F02_2_67738	52456389	1
38211500	F.02.02.A0011_03	23		39416018	L01_2_60486	39416018	1	52456390	F.02.02.A0011_03	22	
	F02_2_67738	38211500	1		L01_3_90714	39416018	1		F02_2_67738	52456390	1
38213002	G.05.02.A0011_01	7	1	39416025	L01_2_60486	39416025	1	52456392	F.02.02.A0011_03	32	
	G05_0_67776	38213002	1		L01_3_90714	39416025	1		F02_2_67738	52456392	1
38213800	F.02.02.A0011_03	9		50956262	D.01.02.A0019_05	4	1	52456706	F.02.02.A0011_03	5	
	F02_2_67738	38213800	1		D.01.02.A0019_06	4		53052175	M01_3_91676	53052175	1
39111608	L01_2_60486	39111608	1		D01_3_59819	50956262	1	53052176	M01_3_91676	53052176	1
	L01_3_90714	39111608	1		D01_4_72864	50956262	1	53143128V	E.01.02.A0011_03	20	1
39111665	L01_3_90714	39111665	1	52156810Z	J.03.02.A0011_00	21	1		E.01.02.A0011_04	19	
39113501	L01_2_60486	39113501	1	52156917	H.01.02.A0011_03	17	1		E01_2_67697	53143128	1
	L01_3_90714	39113501	1		H01_2_67804	52156917	1	53143712	L01_2_60486	53143712	1
39113502	L01_2_60486	39113502	1	52357250	J.01.02.A0011_02	30	1		L01_3_90714	53143712	1
	L01_3_90714	39113502	1		J.01.02.A0011_03	27		53143875V	E.01.02.A0011_03	20	1
39114008	L01_2_60486	39114008	1		J01_1_67885	52357250	1		E.01.02.A0011_04	19	

SPARE PARTS INSTANCE INDEX

Code	Parts Table	Pos.	Q.ty	Code	Parts Table	Pos.	Q.ty	Code	Parts Table	Pos.	Q.ty
53143875V	E01_2_67697	53143875	1	55157212	J.01.02.A0011_02	12	1	55251686	H01_2_67804	55251686	1
53156150	D.01.02.A0019_05	14	1		J.01.02.A0011_03	6		55251688	H.01.02.A0011_03	37	1
	D.01.02.A0019_06	12			J.03.02.A0011_00	7	1		H01_2_67804	55251688	1
	D01_3_59819	53156150	1	55157213	H.01.02.A0011_03	5	1	55252405	C.01.02.A0011_03	2	1
	D01_4_72864	53156150	1		J.01.02.A0011_02	5	1		C.01.02.A0011_04	12	
53156325V	E.01.02.A0011_03	17	1		J.01.02.A0011_03	7			C01_2_67668	55252405	1
	E.01.02.A0011_04	16			J.03.02.A0011_00	11	1	55252406	C.01.02.A0011_03	1	1
	E01_2_67697	53156325	1	55157214	J.03.02.A0011_00	22	1		C.01.02.A0011_04	11	
53156332B	E01_2_67697	53156332	1	55157215	J.03.02.A0011_00	23	1		C01_2_67668	55252406	1
53156332V	E.01.02.A0011_03	6	1	55157609	D.01.02.A0019_05	1	1	55256835	J.03.02.A0011_00	16	1
	E.01.02.A0011_04	6			D.01.02.A0019_06	1		55256836	J.03.02.A0011_00	15	1
53156342V	E.01.02.A0011_03	1	1		D01_3_59819	55157609	1	55257313	J.01.02.A0011_02	28	1
	E.01.02.A0011_04	1			D01_4_72864	55157609	1		J.01.02.A0011_03	37	
	E01_2_67697	53156342	1	55220363	E.01.02.A0011_03	26	1		J01_1_67885	55257313	1
53156346V	E.01.02.A0011_03	17	1		E01_2_67697	55220363	1	55257321	J.01.02.A0011_02	34	1
	E.01.02.A0011_04	16		55242528	J.01.02.A0011_02	4	1		J.01.02.A0011_03	31	
	E01_2_67697	53156346	1		J.01.02.A0011_03	4			J01_1_67885	55257321	1
53156860	J.03.02.A0011_00	6	1		J01_1_67885	55242528	1	552C1001	C.01.02.A0011_04	3	
53243851N	G.05.02.A0011_01	4	1	55243340	H.01.02.A0011_03	8	1	56143865	G05_0_67776	56143865	1
	G05_0_67776	53243851	1		H01_2_67804	55243340	1	56143880Z	G.05.02.A0011_01	25	1
53247488	D.01.02.A0019_05	14	1		I01_2_67839	55243340	1		G05_0_67776	56143880	1
	D.01.02.A0019_06	12		55248038	I.01.02.A0011_03	10	1	56143883Z	G.05.02.A0011_01	17	1
	D01_3_59819	53247488	1		I.01.02.A0011_04	10	1		G05_0_67776	56143883	1
	D01_4_72864	53247488	1		I01_2_67839	55248038	1	56147520Z	E.01.02.A0011_03	4	1
55102678	E.01.02.A0011_03	12	1	55248041	I.01.02.A0011_03	15	1		E.01.02.A0011_04	4	
	E.01.02.A0011_04	14			I.01.02.A0011_04	15	1		E01_2_67697	56147520	1
	E01_2_67697	55102678	1		I01_2_67839	55248041	1	56147655N	I.01.02.A0011_03	4	1
55102714	H01_2_67804	55102714	1	55248283	I01_2_67839	55248283	1		I.01.02.A0011_04	4	1
55142076	J01_1_67885	55142076	1	55248284	I01_2_67839	55248284	1		I01_2_67839	56147655	1
55147842	D.01.02.A0019_05	2	1	55248379	J.01.02.A0011_02	37	1	56147711	I01_2_67839	56147711	1
	D01_3_59819	55147842	1		J.01.02.A0011_03	34		56147845	D.01.02.A0019_05	3	1
	D01_4_72864	55147842	1		J01_1_67885	55248379	1		D.01.02.A0019_06	3	
55156481	D.01.02.A0019_06	2		55249668	H01_2_67804	55249668	1		D01_3_59819	56147845	1
55157212	H.01.02.A0011_03	10	1	55251686	H.01.02.A0011_03	36	1		D01_4_72864	56147845	1

SPARE PARTS INSTANCE INDEX

Code	Parts Table	Pos.	Q.ty	Code	Parts Table	Pos.	Q.ty	Code	Parts Table	Pos.	Q.ty
56147923N	E.01.02.A0011_04	20		56156603Z	I.01.02.A0011_03	2	1	56157393N	C.01.02.A0011_03	10	1
56148037	I.01.02.A0011_03	8	1		I.01.02.A0011_04	2	1		C01_2_67668	56157393	1
	I.01.02.A0011_04	8	1	56156792N	J.01.02.A0011_02	11	1	56157394N	E.01.02.A0011_03	24	1
	I01_2_67839	56148037	1	56156792Z	J.01.02.A0011_03	5			E01_2_67697	56157394	1
56148184	G.05.02.A0011_01	10	1	56156832Z	J.03.02.A0011_00	4	1	56157399N	C.01.02.A0011_03	11	1
56148285	I01_2_67839	56148285	1	56156859Z	J.03.02.A0011_00	19	1		C01_2_67668	56157399	1
56148286	I01_2_67839	56148286	1	56156874N	I.01.02.A0011_03	19	1	56157411Z	H.01.02.A0011_03	27	1
56148287	J.03.02.A0011_00	5	1		I.01.02.A0011_04	19	1		H01_2_67804	56157411	1
56148470N	I.01.02.A0011_03	13	1	56156940	H.01.02.A0011_03	20	1	56157412	H.01.02.A0011_03	30	1
	I.01.02.A0011_04	13	1		H01_2_67804	56156940	1		H01_2_67804	56157412	1
56150361	I01_2_67839	56150361	1	56156948N	H.01.02.A0011_03	12	1	561C1002N	C.01.02.A0011_04	1	
56156119N	C.01.02.A0011_03	13	1		H01_2_67804	56156948	1	56351685	H01_2_67804	56351685	1
	C.01.02.A0011_04	5		56156990V	C.01.02.A0011_03	16	1	56351685Z	H.01.02.A0011_03	34	1
	C01_2_67668	56156119	1		C01_2_67668	56156990	1	56356328	F.02.02.A0011_03	29	
56156195H	J.01.02.A0011_02	14	1	56157234	J01_1_67885	56157234	1		F02_2_67738	56356328	1
	J.01.02.A0011_03	18		56157248	J01_1_67885	56157248	1	56356329	F.02.02.A0011_03	29	
56156261	E.01.02.A0011_03	27	1	56157257	J01_1_67885	56157257	1		F02_2_67738	56356329	1
	E01_2_67697	56156261	1	56157257Z	J.01.02.A0011_02	20	1	56356330	F.02.02.A0011_03	29	
56156276	D.01.02.A0019_05	6	1		J.01.02.A0011_03	11			F02_2_67738	56356330	1
	D.01.02.A0019_06	6		56157271	J01_1_67885	56157271	1	56356331	F.02.02.A0011_03	29	
	D01_3_59819	56156276	1	56157271N	J.01.02.A0011_02	3	1		F02_2_67738	56356331	1
	D01_4_72864	56156276	1	56157274	J.01.02.A0011_02	24	1	56356348	F.02.02.A0011_03	16	
56156281	D.01.02.A0019_05	6	1		J.01.02.A0011_03	23			F02_2_67738	56356348	1
	D.01.02.A0019_06	6			J01_1_67885	56157274	1	56356833Z	J.03.02.A0011_00	8	1
	D01_3_59819	56156281	1	56157282	J01_1_67885	56157282	1	56356840Z	J.03.02.A0011_00	2	1
	D01_4_72864	56156281	1	56157283	J01_1_67885	56157283	1	56356924	H.01.02.A0011_03	2	1
56156284	D.01.02.A0019_05	5	1	56157312	J01_1_67885	56157312	1		H01_2_67804	56356924	1
	D.01.02.A0019_06	5		56157323	J01_1_67885	56157323	1	56359553	L01_2_60486	56359553	1
	D01_3_59819	56156284	1	56157324	J01_1_67885	56157324	1		L01_3_90714	56359553	1
	D01_4_72864	56156284	1	56157324N	J.01.02.A0011_02	35	1	56359554	L01_2_60486	56359554	1
56156285	D.01.02.A0019_05	5	1		J.01.02.A0011_03	32			L01_3_90714	56359554	1
	D.01.02.A0019_06	5		56157332	I01_2_67839	56157332	1	56359593	L01_2_60486	56359593	1
	D01_3_59819	56156285	1	56157349	J01_1_67885	56157349	1		L01_3_90714	56359593	1
	D01_4_72864	56156285	1	56157356	J01_1_67885	56157356	1	563C1005Z	J.01.02.A0011_03	3	



SPARE PARTS INSTANCE INDEX

Code	Parts Table	Pos.	Q.ty	Code	Parts Table	Pos.	Q.ty	Code	Parts Table	Pos.	Q.ty
56443857	G05_0_67776	56443857	1	58043117	E01_2_67697	58043117	1	58051670	I.01.02.A0011_04	25	1
56443871	G.05.02.A0011_01	16	1	58043176	J.01.02.A0011_02	19	1		I01_2_67839	58051670	1
	G05_0_67776	56443871	1		J.01.02.A0011_03	10		58052019	M01_2_67927	58052019	1
56448183	G.05.02.A0011_01	19	1		J01_1_67885	58043176	1	58052029	M01_2_67927	58052029	1
56448196	G.05.02.A0011_01	20	1	58043250	L01_3_90714	58043250	1	58052157	M01_2_67927	58052157	1
56456347	F.02.02.A0011_03	15		58043370	L01_3_90714	58043370	1	58052158	M01_2_67927	58052158	1
	F02_2_67738	56456347	1	58043855	G.05.02.A0011_01	5	1	58052159	M01_2_67927	58052159	1
56456351	F02_2_67738	56456351	1		G05_0_67776	58043855	1	58052160	M01_2_67927	58052160	1
56456475	F.02.02.A0011_03	27		58043874	G.05.02.A0011_01	21	1	58052162	M01_2_67927	58052162	1
	F02_2_67738	56456475	1		G05_0_67776	58043874	1	58052163	M01_2_67927	58052163	1
56456736	F.02.02.A0011_03	13		58043881N	G.05.02.A0011_01	24	1	58052164	M01_2_67927	58052164	1
58002429	I01_2_67839	58002429	1		G05_0_67776	58043881	1	58052165	M01_2_67927	58052165	1
58002538	I.01.02.A0011_03	18	1	58044804	L01_3_90714	58044804	1		M01_3_91676	58052165	1
	I.01.02.A0011_04	18	1	58046912	M02_2_67938	58046912	1	58052167	M01_2_67927	58052167	1
58020258	J01_1_67885	58020258	1	58046932	M02_3_91699	58046932	1	58052183	M01_3_91676	58052183	1
58042167	G.05.02.A0011_01	26	1	58047712	H.01.02.A0011_03	26	1	58052184	M01_3_91676	58052184	1
	G05_0_67776	58042167	1		H01_2_67804	58047712	1	58052185	M01_3_91676	58052185	1
	H.01.02.A0011_03	21	1		I01_2_67839	58047712	1	58052186	M01_3_91676	58052186	1
	H01_2_67804	58042167	1	58048000	I.01.02.A0011_03	6	1	58052187	M01_3_91676	58052187	1
	I01_2_67839	58042167	1		I.01.02.A0011_04	6	1	58052188	M01_3_91676	58052188	1
58042200	I.01.02.A0011_03	27	1		I01_2_67839	58048000	1	58052189	M01_3_91676	58052189	1
	I.01.02.A0011_04	27	1	58048009	H.01.02.A0011_03	25	1	58052190	M01_3_91676	58052190	1
	I01_2_67839	58042200	1		H01_2_67804	58048009	1	58052274	L01_2_60486	58052274	1
	J.03.02.A0011_00	24	1		I01_2_67839	58048009	1	58052280	L01_2_60486	58052280	1
58042202	I01_2_67839	58042202	1	58048012	I01_2_67839	58048012	1	58052281	L01_2_60486	58052281	1
58042219	H.01.02.A0011_03	35	1	58048035	C.01.02.A0011_03	9	1	58052289	L01_2_60486	58052289	1
	H01_2_67804	58042219	1		C01_2_67668	58048035	1	58052297	L01_2_60486	58052297	1
58043053	E.01.02.A0011_03	14	1	58048330	L01_3_90714	58048330	1	58052325	L01_2_60486	58052325	1
	E.01.02.A0011_04	13		58048355	I.01.02.A0011_03	7	1	58052326	L01_2_60486	58052326	1
	E01_2_67697	58043053	1		I.01.02.A0011_04	7	1	58052327	L01_2_60486	58052327	1
58043086	F.02.02.A0011_03	18		58049830	J.03.02.A0011_00	20	1	58053035	I.01.02.A0011_03	26	1
	F02_2_67738	58043086	1	58050345	I.01.02.A0011_03	3	1		I01_2_67839	58053035	1
58043117	E.01.02.A0011_03	18	1		I.01.02.A0011_04	3	1	58056154	I.01.02.A0011_03	20	1
	E.01.02.A0011_04	17		58051670	I.01.02.A0011_03	25	1		I.01.02.A0011_04	20	1

SPARE PARTS INSTANCE INDEX

Code	Parts Table	Pos.	Q.ty	Code	Parts Table	Pos.	Q.ty	Code	Parts Table	Pos.	Q.ty
58056154	I01_2_67839	58056154	1	58057232Z	J.01.02.A0011_03	2		58057722	M02_3_91699	58057722	1
58056155	I.01.02.A0011_03	20	1	58057263	I01_2_67839	58057263	1	58057724	M02_2_67938	58057724	1
	I.01.02.A0011_04	20	1	58057266	H01_2_67804	58057266	1		M02_3_91699	58057724	1
	I01_2_67839	58056155	1	58057273	J.01.02.A0011_02	27	1	58057732	M02_2_67938	58057732	1
58056158	I01_2_67839	58056158	1		J.01.02.A0011_03	36			M02_3_91699	58057732	1
58056164	I01_2_67839	58056164	1		J01_1_67885	58057273	1	58057746	M02_2_67938	58057746	1
58056193	I.01.02.A0011_03	22	1	58057284	I01_2_67839	58057284	1		M02_3_91699	58057746	1
	I.01.02.A0011_04	22	1	58057285	I.01.02.A0011_04	26	1	58057747	M02_2_67938	58057747	1
58056391	F.02.02.A0011_03	11		58057297	I01_2_67839	58057297	1		M02_3_91699	58057747	1
	F02_2_67738	58056391	1	58057329	I01_2_67839	58057329	1	58057748	M02_2_67938	58057748	1
58056593	I.01.02.A0011_03	12	1	58057385	C.01.02.A0011_03	8	1		M02_3_91699	58057748	1
	I.01.02.A0011_04	12	1		C.01.02.A0011_04	13		58057767	M02_2_67938	58057767	1
58056593Z	I01_2_67839	58056593	1		C01_2_67668	58057385	1		M02_3_91699	58057767	1
58056595	I.01.02.A0011_03	17	1	58057401	I01_2_67839	58057401	1	58057768	M02_2_67938	58057768	1
	I.01.02.A0011_04	17	1	58057413	H.01.02.A0011_03	28	1		M02_3_91699	58057768	1
	I01_2_67839	58056595	1		H01_2_67804	58057413	1	58057770	M02_2_67938	58057770	1
	J.03.02.A0011_00	17	1	58057416	I01_2_67839	58057416	1		M02_3_91699	58057770	1
58056815	I.01.02.A0011_03	21	1	58057417	H.01.02.A0011_03	23	1	58057771	M02_2_67938	58057771	1
	I.01.02.A0011_04	21	1		H01_2_67804	58057417	1		M02_3_91699	58057771	1
58056848	J.03.02.A0011_00	3	1	58057418	I.01.02.A0011_03	7	1	58057772	M02_2_67938	58057772	1
58056864	M02_3_91699	58056864	1		I.01.02.A0011_04	7	1		M02_3_91699	58057772	1
58056867	M02_3_91699	58056867	1	58057419	H01_2_67804	58057419	1	58057773	M02_2_67938	58057773	1
58056868	M02_3_91699	58056868	1	58057458	M02_3_91699	58057458	1		M02_3_91699	58057773	1
58056918Z	H.01.02.A0011_03	3	1	58057625	M02_2_67938	58057625	1	58057774	M02_2_67938	58057774	1
	H01_2_67804	58056918	1		M02_3_91699	58057625	1		M02_3_91699	58057774	1
58056942N	H.01.02.A0011_03	13	1	58057676	M02_2_67938	58057676	1	58057795	L01_3_90714	58057795	1
	H01_2_67804	58056942	1		M02_3_91699	58057676	1	58057797	L01_3_90714	58057797	1
58056991	C.01.02.A0011_03	12	1	58057678	M02_2_67938	58057678	1	58057799	L01_3_90714	58057799	1
	C.01.02.A0011_04	4			M02_3_91699	58057678	1	58057839	L01_3_90714	58057839	1
	C01_2_67668	58056991	1	58057688	M02_2_67938	58057688	1	58093089	M02_2_67938	58093089	1
	H.01.02.A0011_03	19	1	58057698	M02_2_67938	58057698	1		M02_3_91699	58093089	1
	H01_2_67804	58056991	1	58057706	M02_2_67938	58057706	1	58147704	I01_2_67839	58147704	1
58057232	J01_1_67885	58057232	1	58057712	M02_2_67938	58057712	1	58150313	I.01.02.A0011_03	9	1
58057232Z	J.01.02.A0011_02	2	1	58057722	M02_2_67938	58057722	1		I.01.02.A0011_04	9	1



SPARE PARTS INSTANCE INDEX

Code	Parts Table	Pos.	Q.ty	Code	Parts Table	Pos.	Q.ty	Code	Parts Table	Pos.	Q.ty
58150313	I01_2_67839	58150313	1	59056920	J.01.02.A0011_02	16	1	59247971	D01_4_72864	59247971	1
58156156	I01_2_67839	58156156	1		J.01.02.A0011_03	20		59248175	G05_0_67776	59248175	1
581C1004	C.01.02.A0011_04	2			J01_1_67885	59056920	1	59256275	D.01.02.A0019_05	15	
59015425	E.01.02.A0011_03	11	1	59056935N	H01_2_67804	59056935	1		D01_3_59819	59256275	1
	E.01.02.A0011_04	15		59056952N	H.01.02.A0011_03	1	1		D01_4_72864	59256275	1
	E01_2_67697	59015425	1		H01_2_67804	59056952	1	59256279	D.01.02.A0019_05	15	
59047709	I01_2_67839	59047709	1	59057010N	H.01.02.A0011_03	9	1		D01_3_59819	59256279	1
59047743	L01_2_60486	59047743	1	59057112	I01_2_67839	59057112	1		D01_4_72864	59256279	1
	L01_3_90714	59047743	1	59057228	J01_1_67885	59057228	1	59256280	D.01.02.A0019_05	15	
59047745	L01_2_60486	59047745	1	59057251	J01_1_67885	59057251	1		D01_3_59819	59256280	1
	L01_3_90714	59047745	1	59057251N	J.01.02.A0011_02	18	1		D01_4_72864	59256280	1
59048181	G.05.02.A0011_01	15	1	59057319	J.01.02.A0011_02	26	1	59256295	D.01.02.A0019_05	15	
59051682	H01_2_67804	59051682	1		J.01.02.A0011_03	35		59256850	J.03.02.A0011_00	13	1
59056051	C.01.02.A0011_03	13	1		J01_1_67885	59057319	1	59256999	H.01.02.A0011_03	18	1
59056051N	C.01.02.A0011_04	5		59057325	J01_1_67885	59057325	1		H01_2_67804	59256999	1
	C01_2_67668	59056051	1	59059551	L01_2_60486	59059551	1	59257151	I01_2_67839	59257151	1
59056089N	C.01.02.A0011_03	13	1		L01_3_90714	59059551	1	59257162	I.01.02.A0011_03	23	1
	C.01.02.A0011_04	5		59059561	L01_2_60486	59059561	1		I.01.02.A0011_04	23	1
	C01_2_67668	59056089	1		L01_3_90714	59059561	1	59257409	H.01.02.A0011_03	32	1
59056111	C01_2_67668	59056111	1	59059571	L01_2_60486	59059571	1		H01_2_67804	59257409	1
59056111N	C.01.02.A0011_03	13	1		L01_3_90714	59059571	1	59259555	L01_2_60486	59259555	1
	C.01.02.A0011_04	5		59059591	L01_2_60486	59059591	1		L01_3_90714	59259555	1
59056258	E.01.02.A0011_03	21	1		L01_3_90714	59059591	1	59259563	L01_2_60486	59259563	1
	E01_2_67697	59056258	1	59247489	D.01.02.A0019_06	14			L01_3_90714	59259563	1
59056259Z	E.01.02.A0011_03	28	1	59247513	D.01.02.A0019_06	14		59259567	L01_2_60486	59259567	1
	E01_2_67697	59056259	1	59247823	D.01.02.A0019_06	14			L01_3_90714	59259567	1
59056365	F02_2_67738	59056365	1	59247884	D.01.02.A0019_05	15		59259578	L01_2_60486	59259578	1
59056394	F.02.02.A0011_03	2			D01_3_59819	59247884	1		L01_3_90714	59259578	1
	F02_2_67738	59056394	1		D01_4_72864	59247884	1	59259580	L01_2_60486	59259580	1
59056707	F.02.02.A0011_03	4		59247924	D.01.02.A0019_05	15			L01_3_90714	59259580	1
59056735N	J.01.02.A0011_03	9			D01_3_59819	59247924	1	59259598	L01_2_60486	59259598	1
59056817V	H.01.02.A0011_03	40	1		D01_4_72864	59247924	1		L01_3_90714	59259598	1
59056824	J01_1_67885	59056824	1	59247971	D.01.02.A0019_05	15		592C1010	D.01.02.A0019_06	14	
59056905	J01_1_67885	59056905	1		D01_3_59819	59247971	1	592C1011	D.01.02.A0019_06	14	



SPARE PARTS INSTANCE INDEX

Code	Parts Table	Pos.	Q.ty
592C1012	D.01.02.A0019_06	14	
592C1013	D.01.02.A0019_06	14	
92243685	L01_2_60486	92243685	1
	L01_3_90714	92243685	1
92457794	L01_2_60486	92457794	1
	L01_3_90714	92457794	1
92459580	L01_2_60486	92459580	1
	L01_3_90714	92459580	1
F0831193010	J.01.02.A0011_02	33	1
	J.01.02.A0011_03	30	
	J01_1_67885	F0831193	1
F0849044070	L01_2_60486	F0849044	1